



ANALYSIS OF PRE-SERVICE AND IN-SERVICE TEACHERS' PERCEPTIONS ABOUT PRACTICAL ACTIVITIES INVOLVING REMOTE LABORATORY

ANÁLISIS DE LAS PERCEPCIONES DE DOCENTES Y ESTUDIANTES GRADUADOS SOBRE LAS ACTIVIDADES DE LABORATORIO REMOTO

ANÁLISE DAS PERCEPÇÕES DE PROFESSORES EM FORMAÇÃO INICIAL E CONTINUADA SOBRE ATIVIDADES ENVOLVENDO LABORATÓRIO REMOTO

Gildo Giroto Junior *  **Ricardo Cenamo Cachichi** ** 
Eduardo Galembeck ***  **Pedro Antônio Muniz Vazquez** **** 

Cómo citar este artículo: Giroto Junior, G., Cachichi, R. C, Galembeck, E., Vazquez, P. A. M. (2022). Analysis of undergraduate students' and teaching professional's perceptions about practical activities involving remote laboratory. *Góndola, Enseñanza y Aprendizaje de las Ciencias*, 17(2), pp. 300-316.. DOI: <https://doi.org/10.14483/23464712.17860>

Recibido: abril 2021, Aceptado: febrero 2022

Abstract

The use of information and communication technologies in education and teacher training is a topic investigated in various areas of knowledge. Recognizing aspects related to pedagogical problematization using specific technologies beyond the technical use of resources in pedagogical practices has also been a concern in this research area. In this scenario, the Remote Laboratories present tools that can contribute to developing experimental practices, incorporating technologies that contribute to the student's scientific education. This work investigates the perceptions of chemistry students and science teachers regarding an activity that involves a practical activity in the Remote Laboratory. Data collection was using questionnaires, analyzed qualitatively through the Discursive Textual Analysis technique. Results show positive perceptions about this type of laboratory in terms of its versatility to face real problems and in environments with few resources and possibilities for pedagogical actions aimed at working with active methodologies, promoting student participation. Most of the negative perceptions refer to aspects that are not directly related to the remote laboratory but are associated with the

* Doutor em Ensino de Ciências, Universidade de São Paulo. USP. Professor da Universidade Estadual de Campinas (UNICAMP) – Campinas, SP (Brasil). Correo eletrônico: ggirotto@unicamp.br - ORCID: <https://orcid.org/0000-0001-9933-100X>

** Doutor em Química Universidade Estadual de Campinas. Professor do Instituto Federal de São Paulo (IFSP) - Hortolândia, SP (Brasil). Correo eletrônico: rcachichi@ifsp.edu.br ORCID: <https://orcid.org/0000-0002-7038-8798>.

*** Doutor em Biologia Funcional e Molecular. Universidade Estadual de Campinas, pós-doutor, University of Pennsylvania - EUA e Purdue University - EUA. Professor Universidade Estadual de Campinas (UNICAMP) SP (Brasil).e-mail: eg@unicamp.br. ORCID: <https://orcid.org/0000-0003-4238-554>

**** Doutor em Química, Universidade Estadual de Campinas. Professor assistente doutor da Universidade Estadual de Campinas. SP (Brasil). Correo eletrônico: vazquez@unicamp.br. ORCID: <https://orcid.org/0000-0002-6149-2841>

investigative nature of the activity. Some perceptions refer to topics to be improved, such as the delay in the experiment transmission. It was possible to promote a process of reflection on the use of these resources.

Keywords: Education and training. Science and technology. Information and communication technologies. Laboratory experiments. Experimentation.

Resumen

El uso de las tecnologías de la información y la comunicación en la educación y la formación de profesores se ha investigado ampliamente en varias áreas del conocimiento. Reconocer aspectos relacionados con la problematización pedagógica para el uso de tecnologías específicas más allá del uso técnico de recursos en las prácticas pedagógicas también ha sido una preocupación en esta área de investigación. En este escenario, los Laboratorios Remotos presentan herramientas que pueden contribuir al desarrollo de prácticas experimentales incorporando tecnologías que contribuyan a la educación científica de los estudiantes. Este trabajo investiga las percepciones de estudiantes de química y de docentes de ciencias con respecto a una actividad que implica el uso de una actividad práctica mediante el Laboratorio Remoto. Para recolectar los datos se utilizaron cuestionarios abiertos, los cuales fueron analizados cualitativamente mediante la técnica de Análisis Textual Discursivo (ATD). Nuestros resultados muestran que existen percepciones positivas sobre el uso de este tipo de laboratorio en cuanto a su versatilidad para enfrentar problemas reales y en entornos con pocos recursos y posibilidades de acciones pedagógicas orientadas a trabajar con metodologías activas, promoviendo la participación de los estudiantes. La mayoría de las percepciones negativas se refieren a aspectos que no están directamente relacionados con el laboratorio remoto, asociadas al carácter investigativo de la actividad. Algunas percepciones se refieren a factores que necesitan mejorarse, como el retraso en la transmisión del experimento. Se logró promover un proceso de reflexión sobre el uso de estos recursos.

Palabras clave: Enseñanza y formación. Ciencias y tecnología. Tecnologías de la información y de la comunicación. Experiencia de laboratorio. Experimentación.

Resumo

O uso das Tecnologias da Informação e da Comunicação na educação e na formação de professores tem sido amplamente pesquisado em diversas áreas do conhecimento. Reconhecer aspectos relacionados à problematização pedagógica para o uso de tecnologias específicas além da inserção técnica de recursos nas práticas pedagógicas também tem sido uma preocupação nesta área de pesquisa. Nesse cenário, os Laboratórios Remotos apresentam ferramentas que podem contribuir para o desenvolvimento de práticas experimentais incorporando tecnologias que contribuem para a aprendizagem dos alunos no ensino de ciências. Se pesquisam as percepções de graduandos de química e professores de ciências a respeito de uma atividade que envolve a utilização de uma atividade prática com o uso de um Laboratório Remoto. A coleta de dados foi mediante questionários

abertos, os quais foram analisados qualitativamente por meio da técnica de Análise Textual Discursiva. Nossos resultados mostram que há percepções positivas quanto ao uso deste tipo de laboratório, quanto à sua versatilidade para lidar com problemas reais e em ambientes com poucos recursos e possibilidades de ações pedagógicas, voltadas ao trabalhar com metodologias ativas e promover o envolvimento dos alunos. A maioria das percepções negativas referem-se a aspectos que não estão diretamente relacionados ao laboratório, como o caráter investigativo da atividade. Algumas percepções referem-se a fatores que precisam aprimorados como o atraso na transmissão do experimento. Foi possível, por meio das percepções encontradas, promover um processo de reflexão sobre a utilização desses recursos.

Palavras chave: Ensino e formação. Ciências e tecnologia. Tecnologias de informação e comunicação. Experiências de laboratório. Experimentação.

1. Introduction

With the emergence and expansion of personal computers and the constant technological evolution since 1980, combined with teaching approaches aimed at student participation in learning, new educational strategies that use Information and Communication Technologies (ICTs) become more present in educational environments. (CAMPBELL, *et al* 2014; COLLINS, HALVERSON, 2010; LEE, LONGHURST, CAMPBELL, 2017). The possibility of using these tools not only promoted insertion in the classroom, but also led to the development of a set of researches focused on investigating their potential and limitations.

In the educational research field, at different levels (primary, secondary and higher education), several projects have been reported in the literature, pointing at learning contributions and tools potentials, evaluating benefits and limitations facing the use of technological resources (CHRISTENSEN, JHONSON, HORN 2008; HUSSAIN, SULEMAN, DIN, SHAFIQUE, 2017; IRBY, BORDA, HAUPT, 2018; MACLAREN, WILSON, KLYMCHUK, 2017). Regarding chemistry, LOCATELLI, TRENTIN (2015) highlight the use of these resources as to the possibility of overcoming difficulties resulting from the learning of complex and abstract concepts.

Chemistry is characterized as an experimental science featuring abstract content often tricky for students to understand and visualize. Therefore, several researchers claim the learning process can be more significant with the use of ICTs, such as application of educational software (PYAT, 2014; [Ochterski](#), 2014), educational games (HESHMATI, KERSTING, SUTTON, 2018; KARAGIORGAS AND NIEMANN, 2017; LAY, OSMAN, 2018), virtual labs for experimental activities (BORTNIK *et al.*, 2017; BALADOH, ELGAMAL, ABAS, 2017; FAULCONER *et al.*, 2018), remote laboratories (CACHICI, 2020, ZACHARIA *et al.*, 2015;), among other tools that may involve problems in context.

However, even with different scenarios for the use of ICTs in the teaching process, the worrying fact is that its use has not been adopted significantly in some educational contexts. Technical reasons are pointed, such as difficult access, teacher training and traditional posture of educators or school management. Besides, other questions are related to the absence of pedagogical problematization for the use of technologies.

Among different existing technological resources, the use of Remote Laboratories / Remote Experimentation (we will use abbreviation RL) presented a growth over the last decade, and different possibilities can be recognized with the use of this resource. As pointed out by GROUT (2017), ALKHALDI, PRANATA, ATHAUDA (2016),

centers that have been developing RL are increasing during the last decades, and some results can be recognized in these practices.

According to Grout (2017), "Remote laboratories are physical laboratories that allow access to experiments within the laboratory by users who would not be in the same physical location as the experiment." DE JONG, LINN, ZACHARIA (2013) argue that RL allows online access to real elements and experiences, differing from simulations, virtual labs, and videos with experiments. In this method, most of those available, remotely manipulating a real system is possible. In this way, students and mediators can, through the network and with devices such as cameras, sensors, and controllers, perform experiments with instruments of a physical laboratory, these being located remotely (MA & NICKERSON 2006).

Considering these first aspects and thinking specifically about experimental practices aimed at teaching chemistry and the use of ICT, the use of remote laboratories can be seen in an interesting way as possibilities for integrating technological resources with pedagogical practices for teaching chemistry. Considering the recent technological tools RL, understanding the impacts of their implementation is important. Therefore, the main objective of this work is:

"Investigate the undergraduate students' and future science teachers' perceptions about an experimental activity proposal aimed at the use of remote laboratories."

To evaluate the pedagogical implications associated with the practice, access the perception is essential to recognize potentials and limitations, considering its possible implementation from the pedagogical point of view. For this reason, we pose as research questions:

- What potentials and limitations are stated by students and teachers regarding the use of remote laboratories?
- How can perceptions support the improvement of teaching practices with the use of remote laboratories?

1. Theoretical framework: Remote laboratories in educational practices

Considering the use of technological resources, it becomes necessary to think about their uses in a way that does not characterize their implementation only as technical artifacts. Therefore, it is considered essential to problematize technologies as part of a pedagogical proposal.

Discussions about the development and objectives of the use of ICT have been, over the years, widely discussed in the political, economic, and social spheres considering the impacts on the current way of life and the means of industrial production (CASTELLS 1999; TOURAINÉ 1994). The restructuring of the new forms of production and social involvement has been considering the insertion of new technologies and, due to their presence in all social spheres, the environment of formal education, be it primary or higher education, cannot be exempted. In this sense, different authors have brought proposals investigating the possibilities of using technologies in education.

LEVY (1998, 1999) points to the concept of cyberspace where he discusses the constitution of learning through what he calls "anthropological space" in which collective intelligence produces a "democratic knowledge space." Although the term democratic (in the digital environment) can be questioned in the author's works, it must be considered that the new accesses are, in fact, possibilities for new actions and interactions in the pedagogical scope. In another perspective, SANTAELLA (2013) brings discussions about the relationships between the different languages used in information networks and the possibilities regarding the use of new media for learning.

When referring to the pedagogical problematization for the use of ICT, we agree with the discussions promoted by CARDOSO, GURGEL (2019) that highlight the importance of considering the social role of education, integrating concepts of teaching and learning based on scientific and technological literacy (SASSERON, 2011; GIL-

PEREZ, VILCHES-PENA, 2001), in education as a form of emancipation (FREIRE, 1980), is an approach related to educational psychology and in the use of active methodologies. Besides, the authors seek the use of technology not only as a technical resource, placing it in a broader context of reflection on its insertion in the educational project.

With the perspective of investigating the use of technological resources in teaching, one of the possible ways is to propose studies that seek, through the planning and evaluation of actions, to understand how they can be integrated into teaching and investigate their consequences in science classes. Therefore, it is necessary to overcome the idea that the insertion of technological resources applies only to the replacement of other forms of teaching, but that involve, in addition to the knowledge of the use of technique, the recognition of its particularities and how its insertion articulates with objectives proposed educational activities.

Considering activities related to the use of Remote Laboratories, we can highlight that there are possibilities to promote the individuality of each student, real experience instead of simulations or recordings, making some kind of experiments more accessible to several institutions, and contributions student autonomy. Other associated factors have been pointed out by authors about flexibility benefit, students' mobility, and motivation, the use of experimentation in theoretical disciplines is possible as a way of introducing them to real labs (LOWE, NEWCOMBE, STUMPERS, 2013). Also, RL allows conducting experiments with long duration and studying phenomena that have these characteristics as, for example, systems for monitoring climate variables or time-dependent transformations.

Considering the questions related to the pedagogical articulation for the use of ICTs, RL in particular, different studies related to the implementation of remote laboratories have been developed and may provide subsidies for new research. There are works aimed at disseminating elaborate systems, studies seeking to understand

the kind of guidance related to this tool use, some professional's perceptions seeking a survey of significant difficulties in implementation as well as those who work studying students' learning (VILES, GALEMBECK, 2017).

ZACHARIA et al. (2015) bring a survey with guidelines to work with remote laboratories on a context of learning based on questioning. These authors made contributions to recognize the need and main features and present recommendations that might be worked towards the use of this resource. In other scenario, LOWE and collaborators (2013) analyze the contributions to the use of RLs by teachers and students from public and private schools in the Australian education context. They point out that, in general, there is a high acceptance for the use of tools, and some materials and logistics-related issues as limitations to overcome.

HERADIO, DE LA TORRE, DORMIDO (2016) bring a review in which they seek answers to questions related to the use of RL, such as their definitions, differences between different types of laboratories (Local access-real resource, Local access-simulated resource, Remote access-real resource, Remote access-simulated resource). Their work also presents initiatives to disseminate RLs, reporting various institutions that deploy remote laboratories, types of laboratory (real or virtual), and whether they are open or not.

BRINSON's study (2015), made a comparison between the use of traditional and remote laboratories. The work points out that most studies of this nature show that students' learning is equal or higher with the use of RL concerning the traditional laboratory. In both cases, were assessed knowledge and content understanding, research skills, practical skills, perception, analytical skills, and social and scientific communication.

The highlighted studies and others reported provide a set of data regarding the characteristics of the use of RL, allowing us to glimpse other research scenarios. When considering studies, we recognize the importance of understanding how professionals and students evaluate the use of

pedagogical proposals that involve the use of RL. Understanding teachers, researchers and students' perceptions make it possible to confront data with other projects developed in other institutions and to expand research regarding RL to overcome any obstacles, adapt systems to the reality of teaching in which it is proposed, and to substantiate the use of RL.

2. Research Methodology

The research can be classified as qualitative research, where the data were collected in a natural environment and the context involves a practice in a real scenario promoting the reflective process by the participants aiming for transformations within the context itself (TIVIÑOS, 1987; MILES HUBERMAN, 1994).

With a focus on recognizing the perceptions of students and teachers, a central objective of our investigation, access to data was performed through the use of a discursive questionnaire (QA) involving two questions (QD1 and QD2) related to participants' perception concerning positive and negative aspects of using remote experimentation, and six other optional questions addressed aspects of whether the activity allowed students to understand the content, system operation, infrastructure and resources, and potential benefits of the activity. Both parts sought to recognize participants' views about the activity experience, listing limits, and possibilities related to aspects of learning and issues related to the resources and techniques used. The questions used were:

QD1: If there are any, cite positive aspects/benefits in using this kind of activity in education

QD2: Main question 2: If there are any, cite negative aspects/disadvantages in using this kind of activity in education

Comment about:

1. Did the experiment make it possible to understand the content?
2. Did the experiment supplement lectures?
3. Were experimental procedures clear?
4. Were used resources adequate?

5. Was the infrastructure used adequate?

6. Does this type of activity benefits students?

The data from questions were analyzed, aiming to recognize responses according to Textual Discursive Analysis (TDA) in which the incidence of records (units of meaning) with the proximity of meaning produces categories to be interpreted by the researcher (MORAES, GALIAZZI, 2007). The process of performing the TDA is similar in part to the coding data process described by CRESWELL (2012), which consists of reading the materials, involving identifying text segments creating codes (units of meaning) that are grouped by similarity of meaning and later associated in themes or categories. In TDA, the same unit can be part of different categories. After the creation of the categories, the authors weave the interpretation, constructing what is called metatext articulating the information and interpretations with the theoretical references, producing the interpretations of the studied subject.

Through data originating from a real teaching context, we seek to weave interpretations that could contribute to the adequacy of resources and improvement of the process of implementing activities involving RL and, in this way, to seek answers to research questions.

3.1 Research context

Data in this study are the result of activities conducted in two different contexts. First was an Experimental Activities discipline for a graduate course in Science and Mathematics Teaching in a public university located in the state of São Paulo, Brazil. The discipline dealt with the history of the use of experimentation and discussed strategies for its use. In this discipline, one of the topics discussed was the use of RL.

Students enrolled in this discipline (total of 24 students) attended a master's or doctorate degree in Science and Mathematics Education with an emphasis in one of the following modalities – Chemistry, Physics, Biology, Mathematics, Education, and Geosciences. Due to features of the

Program, a large part of the master and doctoral students worked as a teacher or had already taught in public or private schools of primary education (for students aged 6 to 14 years old) or high school (for students aged 15 to 17 years old). In this context, the public were teachers, future teachers, or researchers in Science and Mathematics Education field. This group was named P. We recognize the importance of these subjects' perceptions of the activity since they present a critical view of the process from a teaching professionals' perspective (teachers and researchers).

The second group was composed of students pursuing a Bachelor's degree in Chemistry in a Physical-Chemistry II class (compulsory course subject), which is taught regularly in the sixth period of undergraduate course and thus represented students with experience in various disciplines of experimental nature. This group had a total of 42 participants. This group was called S. For this second group, an undergraduate students' look was sought, aiming to recognize difficulties, limitations, and possibilities they pointed on the use of a remote lab.

The goal of looking at remote experimentation in different environments did not consist of comparing perceptions of different groups, since they are beings with different experiences and different goals within their contexts. We sought to identify possibilities and limitations pointed by these groups on a teaching proposal involving the use of RL and believing that both groups can provide subsidies to improve the activity developed and, as a result, data for understanding the limits and possibilities of this proposal. It should be noted that there are ongoing investigations considering other groups, such as students and teachers of primary schools and education networks, students, and teachers of technical level in public and private contexts.

3.2 Developed experimental activities

Both activities involved a similar operating system and approach in which an issue was presented, the experiment that would be carried out was

discussed, and, after carrying it out, the hypothesis was raised to solve the problem.

The board used was an Arduino UNO with a serial link to an ESP8266 board, which provided a Wi-Fi connection to the internet. A detection system was mounted with a red laser (660nm) of 5.0 V (powered by the board) aligned with a LDR sensor of 10 k Ω (light dependent resistor), connected to an analog to digital port on the board. The electronic circuit for this experiment is outlined in Figure 1.

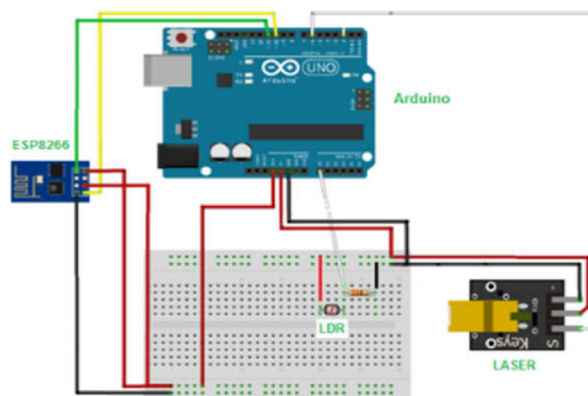

Figure 1. Circuit used for detecting the solution turbidity.

Group P experiment

In group P, an experiment was conducted consisting of an oscillating reaction known as the Briggs–Rauscher. This reaction oscillates over time between amber and blue colors, and depending on reagents concentration, the alternation between colors can be faster or slower. The experiment was accomplished in two different ways: with more concentrated or diluted reagents. The first one had different speeds from second, and the objective was to investigate variables that could have changed from one scenario to another.

In this experiment, the learning management platform Moodle was used to link the video system (via YouTube) and data by inserting Iframes. The video streaming presented approximately 15 seconds lag due to network and site performance.

Group S experiment

In Group S, the experiment was developed to determine the reaction order of thiosulfate ion reacting with hydrochloric acid, and students had not attended any previous theoretical lesson about the experiment. Thus, the idea was to develop the concept of determining the rate law for the reaction, and a subject regularly worked in the discipline. This reaction was explicitly designed for this topic, as it was of interest to develop concepts that were usually approached in a theoretical expository way, through a proposal involving remote experimentation.

The transmission was attended by a mediator professor, and a Moodle link was used, which showed the undergoing experiment through YouTube aside with a percentage graph of luminous intensity as a function of time, almost in real-time. A lag of 10 seconds was observed for the videoed. To minimize possible misunderstandings about this experiment, before it started, the mediator professor showed a video of the reaction, so students could understand what information would be acquired during the experiment.

Table 1. Categories and descriptions for positive aspects and benefits of the activity for Group P.

Positive aspects - Group P	
Category	Descriptions (units of meaning)
CP1. Possibility/accessibility to experimental/practical activities, even with a lack of resources (10 references)	"It provides practice to classroom students who do not have laboratories" / "It provides access to students to real experiments, especially in schools that do not have the possibility (...)" / "Time availability, flexible hours and reduced costs" / "Reduced cost and possibility of organizing an experimental activity without features present in school" / "Remote experiments can be remade several times, and with the ease of already being assembled."
CP2. Contributions to teachers' professional practice (8 references)	"Allows diversification of pedagogical practice; contact with State-of-the-art technology"/"Allows teachers to use hard-to-access resources" / "an excellent tool for pedagogical support when we do not have the possibility to perform an experimental activity at school, or even participate in field practices" / "Allows you to integrate technology to the classroom and to extend class after formal meeting" / "I also think it is valid for distance education, where contact with laboratories is limited."
CP3. Contributions to students' teaching-learning (8 references)	"It makes the student participate in class and interact with each other and with the teacher" / "Students can practice more actively in experiments and technology" / "Greater proximity to technological means (digital literacy)" / "work with digital equipment" / "ability to interact with technology-generating poles, bringing students closer to basic education at university" / "Student can handle, and check obtained results, thus confirming what he/she learned in theory."

Source: the authors

3. Results

A TDA technique was used to analyze the answers for both groups. This analysis of the data allowed the creation of themes or emerging categories. Answers to all questions were considered to create the units of meaning and production of the categories. The analysis was performed separately,

considering the specificity of each group **Textual Discursive Analysis – Group P**

Regarding graduate students' answers, through reading questionnaire responses, six initial categories emerged, three associated with positive aspects and possibilities of using the RL, and three initial categories were associated with negative

aspects and limitations associated with the use of the RL. The categories were named CP1, CP2, CP3, CP4, CP5, and CP6). These categories and some detailed descriptions (units of meaning) are presented in Tables 1 and 2. In total, eighteen questionnaires were obtained.

In the process of building analysis by TDA, there is sometimes a need to create intermediate categories that are reinterpreted into final categories. In our data, the first categories could be worked on as final categories because they pointed to distinct and representative aspects.

Units of meaning for each category show, in general, that participants consider the experiment as a valuable educational tool and understand remote experiment as a form of access in places with no resources, contributing to pedagogical practice and students' learning, as well as promoting to students contact and handling of technological resources.

Some quotes propose ideas disagreeing with RL and refer to the concept of the experiment as theories verification. In the quote, "*Remote experiments can be remade several times and with the ease of already being assembled,*" there is a prospect that any experiment will be available for repetition, a fact that does not match a few remote experiments. Quote "*Student can handle, and check obtained results, thus confirming what he/she learned in theory*" presents the idea of the experiment as proof of a theory, which can be sourced from a traditional experiment conception. This relation is common among teachers and has already been pointed out by other authors (ARROIO, 2006; GORMALLY *et al.*, 2009; ROTH, ROYCHOUDHURY, 1993). However, a critical perception of RL must be developed, so as not to conceive it as a reproduction of traditional practice, under risk to minimize proposal benefits.

Table 2. Categories and descriptions for negative aspects and disadvantages of the activity for Group P.

Negative Aspects – Group P	
Category	Descriptions (units of meaning)
CP4. Resources (8 references)	"Need for computers and good quality internet access can be a barrier" / "It depends on good internet signal. Does not provide appropriate viewing angles" / "Regarding variables control or variation possibility of initial conditions."
CP5. Negative aspects of pedagogical practice (9 references)	"Use depends on teacher's preparation a priori" / "It depends on teacher's preparation to perform the activity, how he/she will work content" / "(can generate) Pedagogical ineffectiveness if applied disassociated from conventional practical activity or out of context" / "Does not replace physical laboratory."
CP 6. Negative aspects for students (8 references)	"Creating and testing hypothesis may be more restricted than in an experiment done in person" / "Lack of teacher and students' participation in assembling and preparing the experiment" / "It does not allow students to manipulate instruments as well as assembly and preparation" / "Students can get distracted with greater ease and important concepts may pass unnoticed."

Source: the authors

When analyzing the categories in general, we see that there is a recognition of the use of RL as a way of using different resources when physical

experimentation is not available, but also notes that indicate the use of RL as a possibility of integrating new actions into practice that promote interaction

between students and students with technology. In this sense, it is possible to consider that the use of RL can be planned along with a practice that involves active teaching strategies together with the use of technologies thinking about the technological appropriation of students and professionals (SAMPAIO, COUTINHO, 2013; VALENTE, 1999;). We are not saying that this is the only possibility of promoting learning with a focus on the interaction between students and between them and the teaching object, but RL can be understood and planned as a strategy to contribute in this direction.

Emerging categories that highlight negative aspects and disadvantages related to the practice, together with some of the units of meaning, are shown in Table 2.

While they point RL as a possibility in environments without physical and material resources, there is a new demand that arises regarding available technological resources in educational institutions. For developing activities that make use of RL, schools, and students must have access to the internet and devices, one of the barriers to the use of RL. Among different researches on the use of ICTs in education and the current status of their use, results have been found to help understand these quotes from teachers.

Different authors point out lack of resources as one of the leading causes of non-use of ICTs in Brazil (place where the research took place) (JUNIOR, CINIRO, 2016), followed by initial and continued training (teacher preparation and understanding of approaches), which was mentioned in some of the answers ("*Use depends on teacher's preparation a priori*" / "*It depends on teacher's preparation to perform the activity, how he/she will work content*"). Note that the negative aspects are not opposed to the previously appointed positives.

Another appointment made is concerned about contact with an actual lab. This concern, however, can be assuaged, as the use of RL is not intended to replace the use of actual laboratories, but to promote the use of strategies that make it possible to work with new skills related to the integration of

technologies and the interpretation of data obtained using different systems from those existing for experiments carried out physically.

An important aspect to be highlighted and that we seek to problematize initially refers to the educational objectives of the use of ICT. The use of technological resources cannot be seen as a way to replace strategies that do not use these resources. The preparation and planning of teaching practices with the use of resources must be associated with educational objectives, which in turn must be questioned (CARDOSO, GURGEL, 2019). Without this problematization, we run the risk of incorporating technology as a simple technical artifact and, even, as a way of precarious actions such as the replacement of conventional laboratories.

In this way, an analysis of categories outlined by Group P shows that RL brought private contributions to education, according to participants, such as low cost and actual experiment in places with few resources, and the association between experimentation and technology, as well as for contributions that are also pointed out in other teaching strategies such as pedagogical practice diversification and students' engagement. This analysis also makes us reflect on the need to think about the process of incorporating resources not as a substitution but as different paths, and a problematic fact pointed out by the categories.

Textual Discursive Analysis – Group S

For undergraduate students, the analysis of questionnaires yielded four categories related to positive aspects and possibilities (called CE1, CE2, CE3, and CE4) and four categories referring to negative aspects and limitations (called CE5, CE6, CE7, and CE8) concerning the activity developed. These categories and related descriptions are presented in Tables 3 and 4. In total, forty-two questionnaires were obtained. In the same way, as for the categories of group P, we note that the initial categories could be considered final because they represented distinct and representative aspects.

Table 3. Categories and descriptions for positive aspects and benefits of the activity for Group S.

Positive aspects - Group E	
Category	Descriptions (units of meaning)
CE1. Contributions to learning (8 references)	"I find it extremely interesting for instigating students to investigate how determined reaction behaves kinetically, as well as to approach reality" (...) It enables a greater understanding because it leaves traditional molds (...) / "It tests student's ability to solve experimental problems on their own (...)" / "As the experiment is transmitted in real-time, you can assimilate more easily the concept and (...) understand how data are obtained (...)"
CE2 Working with real problems (13 references)	"Using knowledge acquired in lectures to solve practical problems is possible while providing a real, practical situation, without having direct access to the lab" / "Data can be transmitted to any place, which would be of great help in production and academic research" / "knowledge acquired in lectures to solve practical problems, while providing a real situation (...)" / "It presents real situations in which discipline content can be applied, including using experimental data obtained in real-time."
CE3 Theory and practice relation (25 references)	"It presents real situations in which discipline content can be applied, including using experimental data obtained in real-time" / "(...) it provides contact with experimental part, giving a vision of how to apply content seen in the classroom in an experiment and how to deal with data obtained" / "(...) To be able to see in practice something that is being taught in theory is quite interesting. In this way, content seems to be fixed more effectively."
CE4 use in environments with few resources (8 references)	"... it allows colleges without proper structure to show in a practical way some kind of experiment..." / "it allows experiment analysis when the site has no structure to perform such experiment" / "Live data can be transmitted anywhere (...) if there are no local resources for carrying out experiments."

Source: the authors

When analyzing descriptions for categories CE1 and descriptions, relates to handling real problems. CE2, two significant aspects singled out by students are Undergraduate students associate their noted. The first refers to how the experiment was practice/profession and notice its benefits (production conducted, with investigative character, in which lines, for example), and, in this context, these are students must interpret and decide about how to use characteristics of remote experimentation. data, which brings contributions to intellectually active participation (HAND, NAM, CHOI, 2012; SUART, MARCONDES, 2009). It should be noted that category CE4, and issues related to use in environments where there are not sufficient resources.

These last two categories are consistent with those solutions. It is noted that the students recognized this pointed by group P.

The discipline for which the practice was performed consisted of a theoretical discipline.

Thus, we emphasize that the intention was not to replace conventional experimental practices by RL. The proposal was planned with a focus on research so that students could, based on a real experiment, presented with the use of technologies, develop joint activity proposal. Although we emphasize that our objective was not to conduct investigations to assess student learning, we note that the subjects recognized the objectives of promoting a proposal that was based on problem-solving. The categories and units of meaning that represent the negative perceptions and disadvantages of using RL in the developed practice are shown in Table 4

Table 4. Categories and descriptions for positive aspects and benefits of activity for Group S.

Negative Aspects – Group E	
Category	Descriptions (units of meaning)
CE5. Activity organization / time – 16	"Activity organization also took a long time" / "a disadvantage (...) is time spent waiting for data to arrive and waiting all students finish a step, so the next step of the activity can be started" / "Class time is short for an extensive content. Any problem that occurs can disrupt the flow of content" / "... the slowness of the subject. With this type of activity, it seems much time is spent in a small portion of the menu of discipline content."
CE6. Resources – 5	"This activity should be performed in the computer room, so students can work data better by building graphics" / "Solution turbidity cannot be seen, and activity was down to an analysis of a table" / "I would like to see the experiment happening, we only saw data appearing" / "As the system requires an internet connection, the procedure may not occur as planned."
CE7. Planning – 5	"As the experiment was conducted without base (theoretical), results were not well used" / "Activity was held before a theory lesson on the subject, which left me a little lost" / "I believe there is no disadvantage as long as it is well planned, avoiding any kind of risk to the progress of the discipline."
CE8. There was/there is no disadvantage – 16	"As long as it is not the only way to show content" / "If it replaces practice completely" / "Despite the problem in transmission" / "As well as it is well-planned and that it does not spoils discipline progress."

Source: the authors.

In categories CE5 and CE7, a concern for students was about class time, planning, and fulfillment of discipline programs. Two facts can be related to this. First refers to students' knowledge regarding the general planning of the discipline. Some authors point out that students can assess some aspects but cannot evaluate others regarding educational context (teaching structure and function, teacher's knowledge, pedagogical knowledge, among other factors). In this way, the

teacher must try to make clear the objectives and how the activity is associated with the curriculum of the course so that these aspects are not easily recognized by students (GIROTTO JUNIOR, 2019).

The second point, highlighted with emphasis on CE7, refers more strongly to the investigative nature of the activity. In fact, in many activities with this format, the student must get information

to solve the question problem. Description "*Activity was held before a theory lesson on the subject, which left me a little lost*" shows that students expect theory to understand the experiment, which is common in traditional activities. The possibility that approaches has presented a few moments in which the objectives or procedures have not been entirely clear is not ruled out, as it is a differentiated activity within that educational context. However, there is, as pointed out by some authors, a conservatism in an educational environment that can often generate resistance and confusion in both students and teachers (CONTRERAS, 2002).

Although we can argue in an attempt to justify the problematic issues pointed out by students, they should serve to reflect on the process of implementing new teaching strategies with or without the use of ICT. Recognize and highlight the objectives of inserting practices such as the one promoted should be apparent to those who plan and to the target audience. In this way, the need to recognize the objectives and mechanisms of development must be made clear when thinking about actions.

Other problematic aspects commented on in the responses refer to the quality of the resources. Some aspects directly linked to conducted remote experiments are highlighted in CE6, in which students point out some flaws in the transmission or necessity of experimenting in a computer room. Indeed, it was highlighted in the description of the experiment performed a problem with video transmission. This fact would not be the ideal scenario, and such a problem served to rethink the video transmission system for other executions of the experiment.

About resources, group S highlights the same placement made by group P, which points to the need for features like the internet and computers, even in a current scenario of digital inclusion, in which most of the population has access to the internet and such devices. A concern with structural factors is also noted, showing that Brazilian reality still has a deficit regarding technological resources.

In general, there are some notes about the investigative nature of the activity, some about remote experimentation and technical problems. All differentiated activity generates possible resistances. Video airing showed flaws, which did not compromise the collection and interpretation of data by students, but it should be improved for other transmissions.

4.Final Considerations

Develop practices involving remote laboratories is one of the ways to promote work with technological resources in educational proposals. Considering the perceptions of students and teachers regarding this implementation is important to understand and improve potential pedagogical gains. In this sense, the data accessed allowed to recognize common aspects to other studies and specific issues to the context of the developed research that can collaborate with the discussions on the use of RL.

Using remote experimentation with the studied groups proved to be a viable alternative to conduct educational experiments. However, technical problems related to technological resources that occurred during the experiment and the institutions' access to resources is one of the concerns raised by teachers and students. These statements are aligned with the broader discussions linked to the use of ICTs.

Demands for necessary infrastructure in schools are reduced to devices that access the internet. Even though many schools are still not prepared for this, implementing this infrastructure is indispensable for students' training, and is included in numerous public programs and policies aimed at primary education. This infrastructure, which may eventually be a limitation for carrying out activities, in some schools, is what makes it possible to expand students' engagement with school activities outside school, for example, conducting and monitoring experiments that are time-consuming or that use hazardous reagents to be manipulated by children.

During the realization of experiments described, some adjustments were made regarding the

technology used. Both image and data transmission has been optimized to provide information with a shorter latency period. Currently, we can perform some remote experiments where interaction return time happens in less than 3 seconds for video transmission, and values close to one second for data transmission were reached.

In order to problematize the pedagogical character of the proposal with the inherent potentialities, it is emphasized that students can perceive the use of remote laboratories as a teaching proposal that does not aim to replace the physical laboratory, but rather to develop complementary practices to teaching and learning.

Given data and different works reported, it is possible to consider that this type of technology has great potential to rescue experimentation in science teaching in primary education, without, however, presenting substitutive character to physical experimentation. With the use of RL, the possibility of conducting interdisciplinary experiments that can start from an initial investigative questioning and bypassing by experimental design, which may involve equipment construction for collecting data to be analyzed, to understand what can be learned from prior investigation and experiment performed. The material used for conducting such experiments has quite affordable costs compared to the costs of setting up science labs, contributing to democratization, not just of scientific knowledge, but also of technological knowledge and critical thinking development, depending on how it is employed.

From this technology, the possibility of conducting experiments that are rarely performed in teaching laboratories can be brought to education, expanding opportunities for developing investigative activities. We emphasize that in our study we promote the investigation of actions in a specific scenario. We believe that such data and results may contribute to research in the area, but we emphasize that further investigations, in different contexts are necessary

in order to subsidize the use of remote laboratories.

Finally, the need to express clarity regarding the use of new educational resources or approaches is emphasized. First, because new approaches generate uncertainty both for those who propose its development and application and for students. Second, it is necessary to problematize a proposal considering the pedagogical potential so that the new resources are not used in a purely technical way, which could contribute negatively to the educational process.

Acknowledgment

The authors would like to thank "Espaço Escrita" at the State University of Campinas for the services provided.

5. References

- ALKHALDI, T.; PRANATA, I.; ATHAUDA, R.I. A review of contemporary virtual and remote laboratory implementations: observations and findings. **Journal of Computer Education**, v.3, pp. 329–351. 2016. ARROIO, A.; *et al.* O show da química: motivando o interesse científico. [The chemistry show: motivating scientific interest], **Química Nova**, v.29 número 1, pp. 173-178. 2006
- AVARGIL, S.; LAVI, R.; AND DORI, Y. J. Students' metacognition and metacognitive strategies in science education. In Y. J. Dori, Z. Mevareach, & D. Baker (Eds.), **Cognition, metacognition, and culture in STEM education**, Cham: Springer, pp. 33–64. 2018.
- BALADOH, S. M.; ELGAMAL, A. F.; ABAS, H. A. Virtual lab to develop achievement in electronic circuits for hearing-impaired students. **Education and Information Technologies**, v. 22, pp. 2071–2085. 2017. DOI 10.1007/s10639-016-9532-7
- BORTNIK, B.; *et al* Effect of virtual analytical chemistry laboratory on enhancing student research skills and practices, **Research in Learning Technology**, v. 25, pp. 1–20. 2017. DOI 10.25304/rlt.v25.1968
- BRINSON, J., R. Learning outcome achievement in non-traditional (virtual and remote) versus traditional (hands-on) laboratories: A review of the empirical research, **Computers & Education**, v. 87, pp. 218–237. 2015.

- CACHICHI, R. C.; GIROTTO JÚNIOR, G.; GALEMBECK, E.; SIMONI, J. A.; SCHEWINSKY JUNIOR, J. A. M.; GOMES, D. F. Creation of a Phenol/Water Phase Diagram Using a Low-Cost Automated System and Remote Transmission. **Journal of Chemical Education**, v. 97 número 10 pp. 3667-2672, 2020. DOI <https://doi.org/10.1021/acs.jchemed.0c00070>
- CAMPBELL, T.; *et al* An Examination of the Changes in Science Teaching Orientations and Technology Enhanced Tools for Student Learning in the Context of Professional Development. **International Journal of Science Education**, v. 36 número 11, pp. 1815–1848. 2014. DOI 10.1080/09500693.2013.879622
- CARDOSO, D.; GURGEL, I. Por uma educação científica que problematize a mídia, **Linhas Críticas**, [For a scientific education that problematizes the media, Critical Lines], v. 25, pp. 74-93. 2019.
- CASTELLS, M. **A sociedade em rede**, [The network society]. Paz e Terra. Rio de Janeiro: Brazil, 1999.
- CHRISTENSEN, C.; JOHNSON, J.; HORN, M. **Disrupting class: How disruptive innovation will change the way the world learns**, McGrawHill. New York, NY:United States. 2008.
- CONTRERAS, José. **A autonomia de professores** [The autonomy of teachers] São Paulo: Cortez, 2002.
- COLLINS, A.; HALVERSON, R. The Second Educational Revolution: Rethink education in the age of technology, **Journal of Computer assisted learning**, v. 26 número 1, pp. 18-27. 2010.
- CRESWELL, J. W. **Educational research: planning, conducting, and evaluating quantitative and qualitative research** (4th ed), Pearson. Boston: United States. 2012.
- DE JONG, T.; LINN, M.; ZACHARIA, Z. C. Physical and virtual laboratories in science and engineering education, **Science**, v. 340, pp. 305–308. 2013. DOI10.1126/science.1230579.
- FAULCONER, E. K.; *et al* comparison of online and traditional chemistry lecture and lab, **Chemistry Education Research and Practice**, v. 19, 392–297. 2018. DOI 10.1039/c7rp00173h
- FREIRE, P. **Educação como prática da liberdade**, [Education as a practice of freedom]. Paz e Terra. São Paulo: Brazil, 1980.
- GARDNER, P. L. Attitudes to science: a review. **Studies in Science Education**, v. 1 número 1, pp. 1–41. 1975.
- GIL-PÉREZ, D.; VILCHES-PENA, A. Una Alfabetización Científica para el Siglo XXI: Obstáculos y Propuestas de Actuación. [A Scientific Literacy for the XXI Century: Obstacles and Proposals for Action] **Investigación en la Escuela**, v. 43, n1, pp. 27-37. 2001.
- GIROTTO JÚNIOR, G.; PAULA, M. A.; MATAZO, D. R. C. Análisis del conocimiento sobre estrategias de enseñanza de futuros profesores de química: vivencia como alumno y reflexión como profesor. **Góndola, enseñanza y aprendizaje de las ciencias**, v. 14, pp. 35-50, 2019. DOI <https://doi.org/10.14483/23464712.13123>
- VILES, I. E. C.; GALEMBECK, E. Laboratorio constructivista y remoto: secuencia didáctica potencialmente significativa para la formación continuada del profesor de ciencias en latinoamérica. **Enseñanza de las ciencias**, v. Num. Extra, p. 2485-2490, 2017.
- GORMALLY, C.; *et al* [Effects of Inquiry-based Learning on Students' Science Literacy Skills and Confidence](#). **International Journal for the Scholarship of Teaching and Learning**, v. 3 número 2, pp. 1-22. 2009. DOI 10.20429/ijstl.2009.030216
- GROUT, I. Remote Laboratories as a Means to Widen Participation in STEM Education, **Education Sciences**, v. 7 número 4, pp. 85, 1-18. 2017.
- HAND, B.; NAM, J.; CHOI, A. Argument-Based General Chemistry Laboratory Investigations for Pre-Service Science Teachers, **Educación Química**, n. 23 número 1, pp. 96-100. 2012.
- HESHMATI, S.; KERSTING, N.; SUTTON, T. Opportunities and Challenges of Implementing Instructional Games in Mathematics Classrooms: Examining the Quality of Teacher-Student Interactions During the Cover-up and Un-cover Games, [International Journal of Science and Mathematics Education](#), v. 16, pp. 777–796. 2018 DOI 10.1007/s10763-016-9789-8
- HERADIO, R.; TORRE, L. -DE LA.; DORMIDO, S. Virtual and remote labs in control education: A survey, **Annual Reviews in Control**, v. 42, pp. 1–10. 2016. DOI 10.1016/j.arcontrol.2016.08.001
- HUSSAIN, I. *et al*. Effects of Information and Communication Technology (ICT) on Students' Academic Achievement and Retention in Chemistry at Secondary Level, **Journal of Education and Educational Development**, v. 4 número 1,73–93. 2017.
- [IRBY, S. M.](#); [BORDA, E. J.](#); HAUP, J. Effects of Implementing a Hybrid Wet Lab and Online

- Module Lab Curriculum into a General Chemistry Course: Impacts on Student Performance and Engagement with the Chemistry Triplet, **Journal of Chemical Education**, v. 95 número 2, pp. 224–232. 2018.
- JUNIOR, D. P. F.; CIRINO, M. M. A utilização das TIC no ensino de Química durante a formação inicial. [The use of ICT in teaching chemistry during initial training], **Revista Debates em Ensino de Química**, v. 2, pp. 102-113. 2016
- KARAGIORGAS, D. N.; NIEMANN, S. Gamification and Game-Based Learning. **Journal of Educational Technology Systems**, v. 45 número 4, pp. 499–519. 2017. DOI 10.1177/0047239516665105
- LAY, A.-N.; OSMAN, K. Developing 21st-century chemistry learning through designing digital games, **Journal of Education in Science, Environment and Health**, v. 4 número 1, pp. 81–92. 2018. DOI 10.21891/jeseh.387499
- LEE, H.; LONGHURST, M.; CAMPBELL, T. Teacher learning in technology professional development and its impact on student achievement in science, **International Journal of Science Education**, v. 39 número 10, pp. 1282–1303. 2017. DOI 10.1080/09500693.2017.1327733
- LEVY, P. **A inteligência coletiva: por uma antropologia do ciberespaço. [Collective intelligence: for an anthropology of cyberspace.]** 5a. edition. Loyola. São Paulo: Brazil, 1998.
- _____. **Cibercultura. [Cyberculture].** Editora 34. São Paulo: Brazil, 1999.
- LOCATELLI, A.; ZOCH, A. N.; TRENTIN, M. A. S. TICs no Ensino de Química: Um Recorte do “Estado da Arte.” [ICT in Teaching Chemistry: A part of the “State of Art.”], **Revista Tecnologias na Educação**, v. 7 número 12, pp. 1–12. 2017.
- LOWE, D.; NEWCOMBE, P.; STUMPERS, B. Evaluation of the Use of Remote Laboratories for Secondary School Science Education, **Research in Science Education**, v. 43, pp. 1197–1219. 2013.
- MA, J.; NICKERSON, J. V. Hands-on, simulated, and remote laboratories, **ACM Computing Surveys**, v. 38 número 3, pp. 1–24. 2006. DOI 10.1145/1132960.1132961.
- MACLAREN, P.; WILSON, D.; KLYMCHUK, S. I See What You Are Doing: Student Views on Lecturer Use of Tablet PCs in the Engineering Mathematics Classroom, **Australasian Journal of Educational Technology**, v. 33 número 2, pp. 173–188. 2017.
- MILES, M. B.; HUBERMAN, M. **Qualitative data analysis: an expanded sourcebook**, (2nd. ed.), Sage publications. Califórnia: United States. 1994
- MORAES, R.; GALIAZZI, M. C. **Análise textual discursiva. [Discursive textual analysis]**, Unijuí, Ijuí: Brasil, 2007.
- MORAN, J. M. Mudando a educação com metodologias ativas. [Changing education with active methodologies], in Souza C. A. and MORALES O. E. T. (ed.). **Convergências midiáticas, educação e cidadania: aproximações jovens. [Media convergences, education and citizenship: young approaches]**. Foca Foto-PROEX/UEPG. Ponta Grossa: Brazil, pp. 45-62. 2015.
- [OCHTERSKI, J., W.](#) Using Computational Chemistry Activities to Promote Learning and Retention in a Secondary School General Chemistry Setting, **Journal of Chemical Education**, v. 91 número 6, pp. 817–822. 2014. DOI 10.1021/ed300039y
- PYAT, K. Use of chemistry software to teach and assess model-based reaction and equation knowledge, **Journal of Technology and Science Education**, v. 4 número 4, pp. 215–227. 2014. DOI 10.3926/jotse.110
- ROTH, W. M.; ROYCHOUDHURY, A. The Development of Science Process Skills in Authentic Contexts, **Journal of Research in Science Teaching**, v. 30 número 2, pp. 127-152. 1993.
- SAMPAIO, P. A. S. R.; COUTINHO, C. P. Ensinar com tecnologia, pedagogia e conteúdo. [Teaching with technology, pedagogy and content.] **Revista Científica de Educação a distância**, v. 5 número 8, pp. 1-17. 2013
- SANTAELLA, L. Desafios da ubiquidade para a educação. [Challenges of ubiquity for education.] **Revista Ensino Superior, extra number**, pp. 19-28. 2013. Available in: <https://www.revistaensinosuperior.gr.unicamp.br/artigos/desafios-da-ubiquidade-para-a-educacao>
- http://www.revistaensinosuperior.gr.unicamp.br/edicoes/ed09_abril2013/NMES_1.pdf. Acesso em 10 jul. 2020.
- SASSERON, L. H.; CARVALHO, A. M. P. Construindo argumentação na sala de aula: a presença do ciclo argumentativo, os indicadores de Alfabetização Científica e o padrão de Toulmin [Building argumentation in the classroom: the presence of the argumentative cycle, the Scientific Literacy indicators and the Toulmin

- pattern]. **Ciência e Educação**, v. 17, p. 97-114, 2011.
- SUART, R. C.; MARCONDES, M. E. R. A manifestação de habilidades cognitivas em atividades experimentais investigativas no ensino médio de química. [The manifestation of cognitive abilities in investigative experimental activities in high school chemistry], **Ciência & Cognição**, v. 14 número 1, pp. 50–74. 2009
- TRIVIÑOS, A. N. S. **Introdução a pesquisa em ciências sociais: a pesquisa qualitativa. [Introduction to research in social sciences: qualitative research]**. 1st edition. Atlas. São Paulo: Brazil, 1987.
- ZACHARIA, Z. C. *et al.* Identifying potential types of guidance for supporting student inquiry when using virtual and remote labs in science: a literature review, **Educational Technology Research and Development**, v. 63, pp. 257–302. 2015.
- VALENTE, J. A. **O computador na sociedade do conhecimento. [The computer in the knowledge society]**, UNICAMP/NIED. Campinas: Brazil, 1999.
- TOURAINÉ, A. (1994), **Crítica da Modernidade. [Critique of Modernity]**. Vozes. Petrópolis: Brazil, 1994.

