



UNIVERSIDAD DISTRITAL
FRANCISCO JOSE DE CALDAS

VISIÓN ELECTRÓNICA

<https://doi.org/10.14483/issn.2248-4728>



VISIÓN ELECTRÓNICA

A RESEARCH VISION

Study of the behavior of the photovoltaic panel according to the installed surface. Monocrystalline photovoltaic panel in wood surface and drywall compared to a standard surface panel

Estudio del comportamiento del panel fotovoltaico según la superficie instalada. Panel fotovoltaico monocristalino en superficie de madera y drywall comparado con un panel en superficie estándar

***Javier Gonzalo Ascanio-Villabona¹, Brayán Eduardo Tarazona-Romero²,
Camilo Leonardo Sandoval³***

Abstract

This article focuses on the study of the behavior of electrical variables (Power, Voltage, Current) and the temperature incidence of a monocrystalline photovoltaic panel (PFV), installed on a wooden and drywall surface and another installed on standard surface (Cement), to contrast them, and obtain the behavior of these variables, in order to determine which of the two surfaces on which the monocrystalline photovoltaic panels are installed provides the greatest power.

The methodological phase was advanced on the terrace of the Santander Technological Units,

¹ Electromechanical Engineer, Unidades Tecnológicas de Santander, Colombia. Master in energy efficiency and renewable energies, Universidad a Distancia de Madrid, Spain. Current position: Unidades Tecnológicas de Santander.

² Electromechanical Engineer, Unidades Tecnológicas de Santander, Colombia. Master in energy efficiency and renewable energies, Universidad a Distancia de Madrid, Spain. Current position: Unidades Tecnológicas de Santander.

³ Electronic Engineer, Universidad Industrial de Santander, Colombia. Master in Electronics, Universidad Industrial de Santander, Colombia. Current position: Unidades Tecnológicas de Santander, Colombia.

applying both scientific and comparative research methods, which, a prototype is designed for the measurement of the data by installing elements that constitute a photovoltaic solar system, and measuring instruments for capturing and taking data from the variables to be studied. Data capture is performed for 60 days, for subsequent comparative analysis of each of the electrical variables presented by THE PVFs.

As results of this research, comparative graphs of the electrical and thermal behavior of the photovoltaic panels are obtained on the two installed surfaces. This article focuses on the study of the behavior of electrical variables (Power, Voltage, Current) and the temperature incidence of a monocrystalline photovoltaic panel (PFV), installed on a wooden and drywall surface and another installed on standard surface (Cement), to contrast them, and obtain the behavior of these variables, in order to determine which of the two surfaces on which the monocrystalline photovoltaic panels are installed provides the greatest power.

Keywords: Efficiency, Energy, Photovoltaic, Surface, Temperature.

Resumen: El presente artículo centra en el estudio del comportamiento de las variables eléctricas (Potencia, Voltaje, Corriente) y la incidencia de la temperatura que presenta un panel fotovoltaico monocristalino (PFV), instalado en una superficie de madera y drywall y otro instalado en superficie estándar (hormigón), para contrastarlos, y obtener la conducta de estas variables, para así determinar cuál de las dos superficies en las que se instalan los paneles fotovoltaicos monocristalinos provee mayor potencia.

La fase metodológica se adelantó en la terraza de las Unidades Tecnológicas de Santander, aplicando métodos investigativos tanto científico como comparativo, la cual, se diseña un prototipo para la medición de los datos instalando elementos que constituyen un sistema solar fotovoltaico, y los instrumentos de medición para la captura y toma de datos de las variables a estudiar. La captura de datos se realiza durante 60 días, para el posterior análisis

comparativo de cada una de las variables eléctricas que presentan los PVF.

Como resultados de la presente investigación se obtienen las gráficas comparativas del comportamiento eléctrico y térmico de los paneles fotovoltaicos en las dos superficies instaladas. El presente artículo centra en el estudio del comportamiento de las variables eléctricas (Potencia, Voltaje, Corriente) y la incidencia de la temperatura que presenta un panel fotovoltaico monocristalino (PFV), instalado en una superficie de madera y drywall y otro instalado en superficie estándar (hormigón), para contrastarlos, y obtener la conducta de estas variables, para así determinar cuál de las dos superficies en las que se instalan los paneles fotovoltaicos monocristalinos provee mayor potencia.

Palabras clave: Eficiencia, Energía, Fotovoltaico, Superficie, Temperatura.

1. Introduction

Currently, one of the greatest concerns at the local level has been the great demand for electricity, due to the population increase and the industrial development of the country, followed by large investments in energy, being hydroelectric the most important generation in Colombia.

These energy sources have major disadvantages, as they have caused major energy crises such as the blackout of 1992, or the crisis that occurred in 2015 due to the El Niño phenomenon. [5]

Photovoltaic solar energy is one of the energy sources that has become an alternative solution to these problems, since it is a renewable energy source, does not pollute and can be of great use at the local level. For this reason, it is important to study and develop this renewable energy source to achieve greater incentive and penetration in the local population.

The study of the characterization of the variables that affect the energy efficiency of a photovoltaic panel is a fundamental aspect to achieve a greater development of this energy

source, but when carrying out bibliographic studies about the progress in this aspect, it is possible to evidence the great lag that exists, the little information and progress regarding the improvement of the energy efficiency of this renewable energy source.

A monocrystalline photovoltaic solar panel needs to be in the presence of sunlight to generate electrical energy, so when it is exposed to the sun, the increase of its temperature negatively affects its solar panels, thus decreasing its performance, which is one of the most important causes of the loss of its efficiency.

Therefore, this research focuses on the study of the behavior of the electrical variables of a monocrystalline photovoltaic panel on a wood and drywall surface, compared to another on a concrete surface (Standard), and the effect of the temperature present on the two surfaces to be compared. In order to characterize the electrical variables of the two installation conditions of the monocrystalline photovoltaic panels and to give an initial analysis of their energy efficiency. [6]

For the realization of this project, two prototypes were implemented with photovoltaic systems installed on the aforementioned surfaces with their respective instruments (Regulator, Inverter, Battery), and the measurement system (DC voltammeter meter and digital pyrometer with its respective thermocouple), for data capture, ending with the comparison of data represented in tables and trend diagrams.

2. Location

Based on the fact that the project is investigative, it is carried out at the Technological Units of Santander, located in the city of Bucaramanga, Colombia. As shown in figure 1.

Figure 1. Geographical Location of the Prototype [2].



For this purpose, the prototypes to be monitored are located in the highest area of the institution in order to avoid shadows in the surrounding area, as shown in Figure 2.

Figure 2 Prototype installation plan.

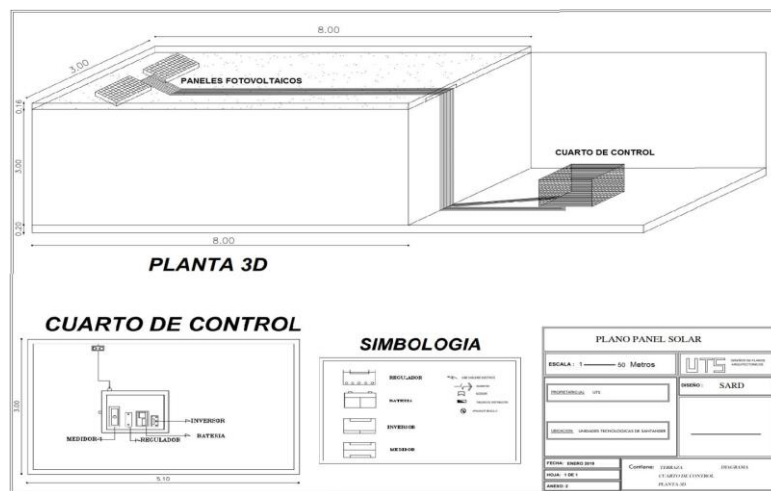

Source: own.

Starting the study of the place where the photovoltaic system will be installed, it is important to make a plan of the area, with their respective measures so that you have a general idea of the installation of all equipment. Figure 2 shows the plan that corresponds to the terrace of building B of the Technological Units of Santander where the photovoltaic panel will be installed with

their respective measures in meters, and the place where the control room will be installed.

3. Methodology

The procedure to be carried out in this project will serve as an initial contribution in the study of the characterization of the variables that affect the energy efficiency of a monocrystalline photovoltaic panel, through the analysis of the behavior of the solar panel on wood and drywall surface with respect to one on standard surface, by means of results that yield the measurement elements (wattmeter, ammeter, voltmeter and thermometer). Based on the above, it can be stated that this research project is descriptive and investigative. It was developed with the phases shown in Table 1.

Table 1. Schedule of Activities.

Phase	Activities
Phase 1 documentation	<ul style="list-style-type: none"> ● To study the behavior of a monocrystalline photovoltaic panel. ● To study the variables that alter the energy efficiency of a monocrystalline photovoltaic panel. ● Investigate the relevant measuring instruments to characterize the variables about the energy efficiency of a monocrystalline photovoltaic panel. ● Study the most appropriate place to carry out the assembly. ● Research on the legal norms in force that regulate the installation and implementation of non-conventional renewable energies.
Phase 2 installation	<ul style="list-style-type: none"> ● Install measurement elements of the monocrystalline photovoltaic panel on wood and drywall surface and on standard surface by means of measuring instruments (wattmeter, ammeter, voltmeter and thermometer) that are intended to be taken to a control board to perform data capture in a more didactic way. ● Installing the monocrystalline photovoltaic panel on the wooden surface and drywall, and on the standard surface on the roof of building B of the Santander Technological Units.
Phase 3 recording of variables	<ul style="list-style-type: none"> ● Collection of data collection for each of the variables. ● Data storage in a document base, created by the authors.
Phase 4 analysis	<ul style="list-style-type: none"> ● Analyze each of the variables by means of the statistical diagram. ● Contrast wood and drywall surface variables with the standard surface. ● Determine if the implementation of the wood surface is feasible and drywall in the installation of a solar panel

Source: own.

Based on the methodology and the activities proposed, the implements for the assembly of the prototype are analyzed and selected to study the system. Figure 3 shows the elements that were used in the implementation of the photovoltaic system, for the subsequent taking of measurements. The 100w monocrystalline photovoltaic panel, the DC volt-ampere meter, necessary for the capture of electrical data that presents both panels, 12V regulator, 12v solar battery, 26A, 400w inverter and the load consisting of a 9w bulb and a 3w temperature controller.

Figure 3 Graphic description of the prototype.

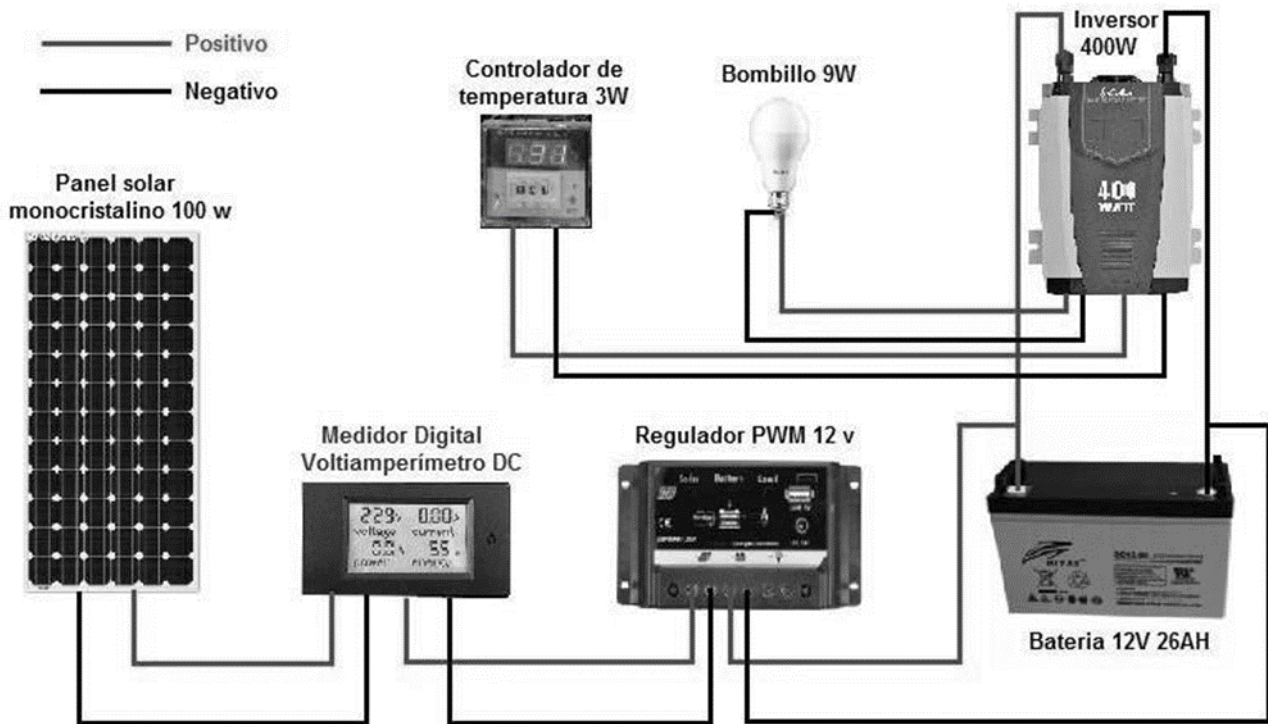

Source: own.

Prior to the installation of the photovoltaic panels, we analyzed and determined the optimal positioning and inclination for the implementation of the photovoltaic panels in order to have the best use of solar radiation, and better study conditions of the surfaces where the monocrystalline photovoltaic panels will be installed, to obtain greater objectivity in the evaluation of the impact of the surfaces (Wood and Drywall and Standard) on the efficiency of

the photovoltaic panels.

The latitude of the place where a photovoltaic panel is installed is extremely important to determine its most appropriate inclination, since it depends on this the inclination that should be given to the photovoltaic panel. The latitude is the distance between any place and the equator line, which is measured in degrees.

In Bucaramanga, the latitude is $7^{\circ}07'31''$ N (Geodata), so the inclination of the photovoltaic panels is approximately 7° , but a minimum inclination of 15° is recommended to avoid the accumulation of dust and water. For the purposes of this project, it was decided to implement the panels without any inclination, i.e. completely horizontal, since it does not affect to a great extent the use of the sun, due to its low inclination (7°) due to the latitude present in the city of Bucaramanga. In addition, in the case of implementing a photovoltaic panel with some inclination, it would affect the study of the surface, since the distance between the surface and the photovoltaic panel would not be uniform, and the wind would penetrate altering the temperature between the surface and the panel. Due to the fact that the photovoltaic panels will be positioned completely horizontally, the dust and rainwater that accumulates on them will be cleaned so as not to affect their energy efficiency. [4-5]

4. Results

The first step in the installation process corresponds to the implementation of the wood and drywall surfaces and the standard surface, essential to contrast the behavior of each of the variables (voltage, current, power and temperature) to be studied.

The two surfaces are positioned completely horizontal, and are at a height of 40 cm from the ground, to prevent air from penetrating between the surface and the photovoltaic panel, it also has a length of 140 cm and a width of 70 cm, covering an area larger than that of the

photovoltaic panels, so that the surface or base implemented directly affects the electrical variables supplied by the photovoltaic panels to be studied.

The wood and drywall base features wood on top and drywall on the bottom as shown in Figure 4, which is common in the ceiling sheathing of some homes. Because drywall consists of gypsum board laminated between two layers of cardboard, it is susceptible to water, causing it to deteriorate rapidly. It is for this reason that it is placed on the underside so that it is protected by the wood to ensure that the surface can be maintained in optimal condition during the 60 days of study.

Figure 4. Wood and Drywall surface.

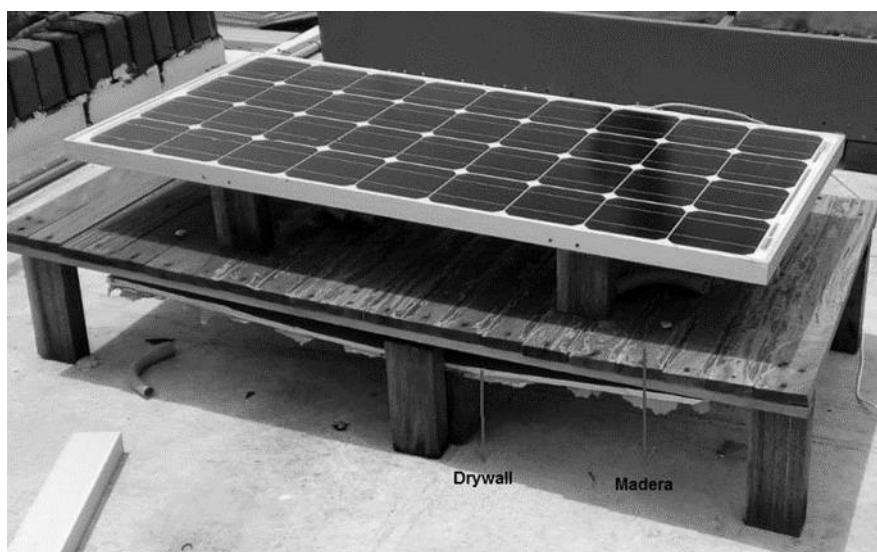

Source: own.

The standard base consists of the floor covering of the terrace where this project was executed as shown in Figure 5, which is made of concrete, being very common in the installation of solar panels on buildings and houses, as it is the point where you can take advantage of solar radiation without shadows, this surface is implemented to contrast the behavior of the variables of the 100W monocrystalline photovoltaic panel, with that of the wood and drywall surface.

Figure 5 Standard Surface (concrete).

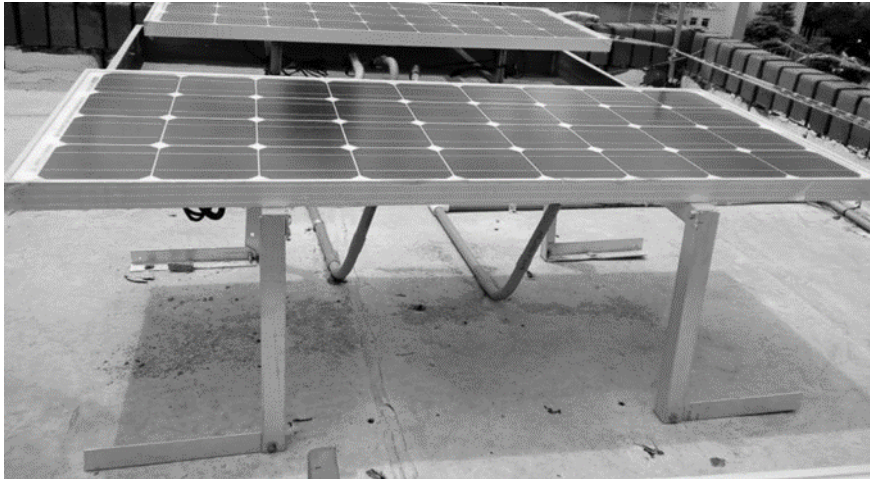

Source: own.

The monocrystalline photovoltaic panels implemented for this project are mainly composed of very high purity silicon, so they have high efficiency, in addition to having greater capacity to absorb solar radiation in situations of low light exposure. [7]

These photovoltaic panels consist of a lamination with tempered glass to protect the panel, junction box with their respective connectors, and have long life because they withstand different environments such as strong winds, hail and storms. The power of the implemented photovoltaic panels corresponds to 100W, because its size is appropriate for its installation generating greater comfort for its later study.

4.1. Acquisition of variables.

The storage of each of the captured measurements was done in an orderly manner by tabulating in tables, which recorded the time, date and each of the measured variables (Voltage, Current, Power and Temperature). The beginning of the data capture starts on day 0 so that it is carried out in the stipulated period of 60 days, for its eventual analysis. Table 2

shows an example of the database used for the measurements of the photovoltaic panel on wood and drywall surface, and on standard surface, respectively.

Table 2 Example of data tabulation.

HORA	8:00 a. m.				12:00 M				5:00 p. m.			
Dia	Voltaje (V)	Corriente (A)	Potencia (W)	Temperatura (°C)	Voltaje (V)	Corriente (A)	Potencia (W)	Temperatura (°C)	Voltaje (V)	Corriente (A)	Potencia (W)	Temperatura (°C)
1	12,45	2,1	26,1	33	13,92	3,83	53,3	34	12,81	0,39	5	41
2	12,56	1,78	22,3	30	14,13	3,49	49,3	38	13,34	0,58	7,7	39
3	11,94	2,43	29	32	13,47	3,7	49,8	40	12,51	0,16	2	41
4	12,7	2,31	29,3	29	14,56	4,59	66,8	37	13,03	0,34	4,4	39
5	12,38	1,87	23,1	32	13,36	4,67	62,3	34	12,76	0,23	2,9	36
6	12,89	2,53	32,6	35	14,47	3,64	52,6	34	13,05	0,65	12,4	39
7	12,31	1,7	20,9	30	12,69	3,19	40,4	35	12,63	0,45	5,7	42
8	12,22	2,11	25,7	35	14,46	3,92	56,6	37	12,73	0,38	4,8	40
9	12,44	3,32	41,3	25	11,62	2,32	26,9	37	12,89	0,48	6,1	41
10	11,62	2,12	24,6	27	11,37	0,99	11,2	41	12,76	0,41	5,2	40
11	12,39	3,43	42,4	34	12,86	5,45	70	40	12,37	0,21	2,6	42
12	--	--	--	--	--	--	--	--	--	--	--	--

Source: own.

Beginning the interpretation of the data, the graphical representation of each of the electrical variables (voltage, current, power) of both photovoltaic panels compared with both temperatures was made in order to analyze the impact of temperature on each of the variables mentioned above.

These graphs were made using a graphical tool, where for ease of statistical interpretation, 2 linear graphs were implemented to contrast the trend of each of the variables (y-axis) during the 60 days of data collection (x-axis). The first graph shows the continuous lines of the electrical variable of the two monocrystalline photovoltaic panels, while the second graph shows both continuous lines of the temperature present on the surface of both photovoltaic panels during the 60 days, so that the incidence of the temperature of both panels on the

electrical variables can be contrasted and analyzed. Due to the fact that the data collection was carried out in 3 different schedules (8:00 am, 12:00 m and 5:00 pm) it was necessary to make independent graphs for each of these 3 schedules.

The temperature was used to be compared with the electrical variables belonging to the two photovoltaic panels, where it is possible to observe the trend of the temperature between the two photovoltaic panels and the surfaces (wood and drywall and standard) at 8:00AM during the 60 days, where it is evident that the line corresponding to the temperature of the standard surface (Red) remained above the temperature of the photovoltaic panels line of the wood and drywall surface (Blue) during the 60 days . on the other hand it is observed that the peak temperature was 41 °C, corresponding to the standard surface, while the day where there was lower temperature corresponding to the wood and drywall surface where a temperature of 24 °C was supplied, as evidenced in Figure 6.

Figure 6. Comparison of temperature behavior (Data collected at 8:00 am).

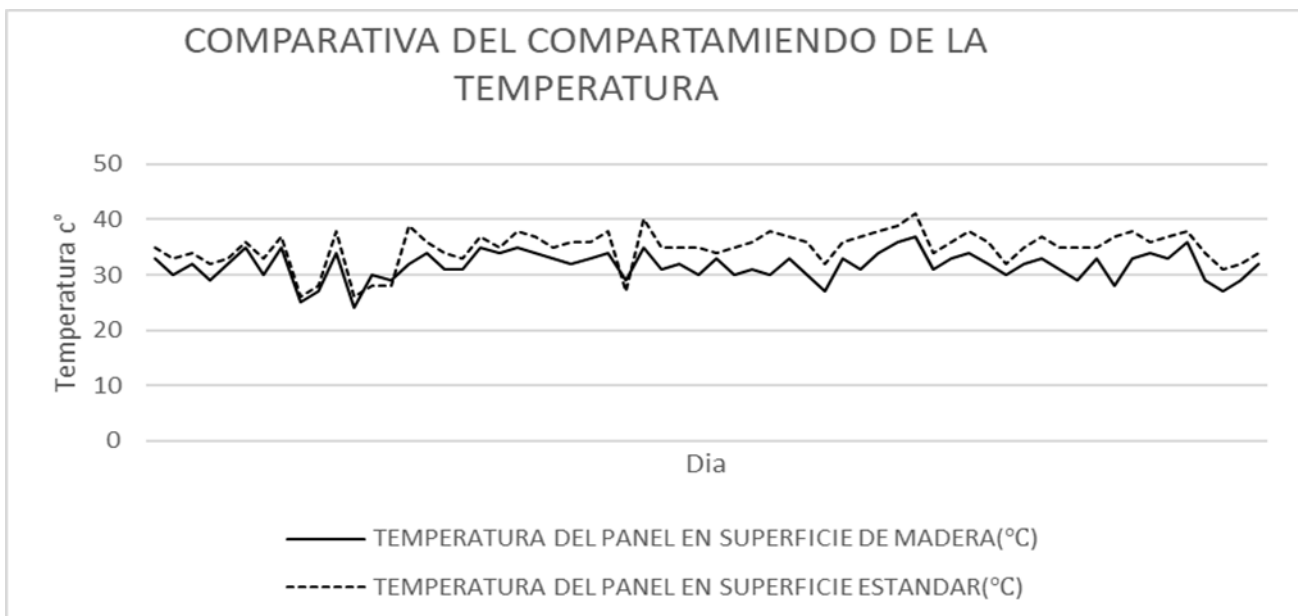

Source: own.

Regarding the power at 8:00 AM, it can be seen in figure 6, that the peak power was 52.4 W, for the wood and drywall surface panel. While the lowest power was 4.6 W supplied by the standard surface panel on the same day.

Figure 7. Comparison of electrical power generated (Data collected 8:00 am).

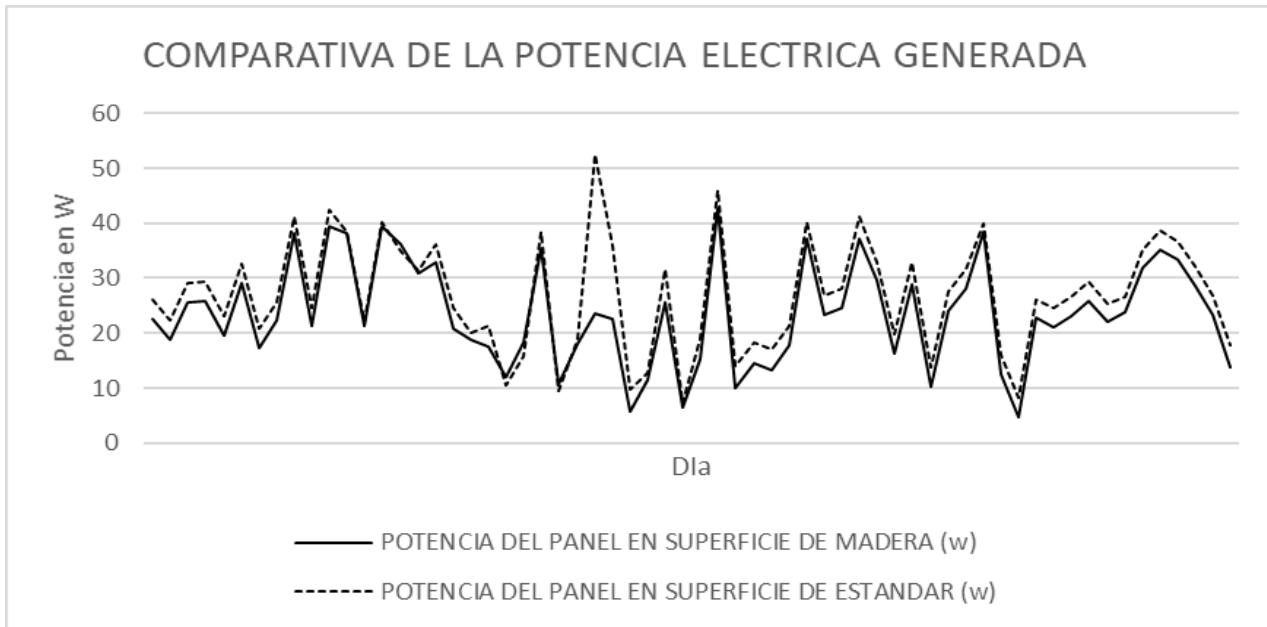

Source: own.

The temperature trend at 12:00 m. served as a reference for comparison with respect to the electrical variables. It is evident that the line corresponding to the standard (red) remains above the temperature line of the wood and drywall surface (blue) during the 60 days of measurements. The peak temperature was 48 °C corresponding to the standard surface, while the lowest temperature was 26 °C corresponding to the wood and drywall surface, which can be seen in figure 8.

Figure 8. Temperature comparison (Data collected at 12:00 am).

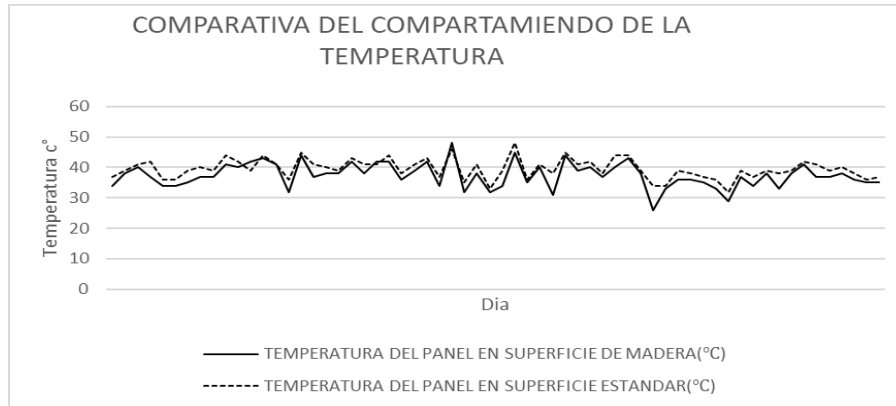

Source: own.

With respect to the power, it can be seen that the peaks are higher during the 12:00 hours. The peak power was 74.4 W, for the wood and Drywall surface panel, while the lowest power supplied was 5.8 W for the Standard surface panel, shown in Figure 9.

Figure 9. Comparison of electrical power generated (Data collected at 12:00 m).

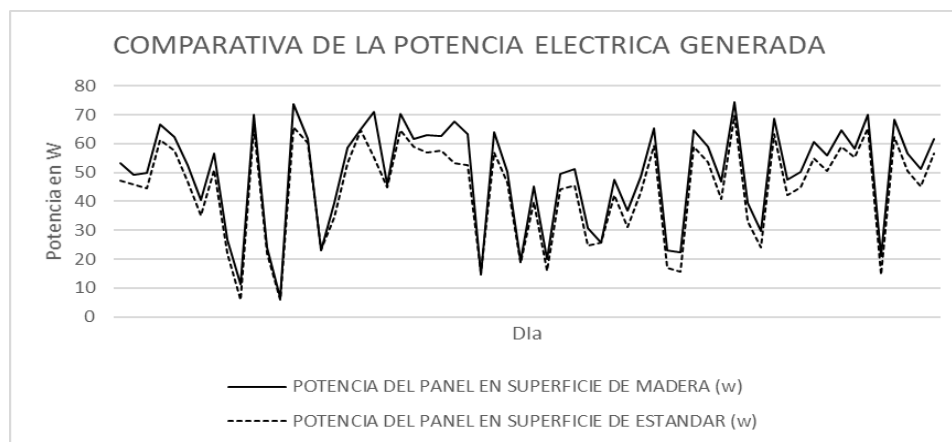

Source: own.

The trend of the temperature at 5:00 p.m. was made to compare it with respect to the electrical variables. It is achieved to evidence that the line corresponding to the standard (Red) remains

intertwined with the line of temperature of the wood and drywall surface (Blue) during the 60 days of measurements. The peak temperature was 46 °C corresponding to the standard surface, while the lowest temperature was 34 °C corresponding to the wood and drywall surface, which can be seen in figure 10.

Figure 10. Comparison of the temperature generated (data collected at 5:00 pm)

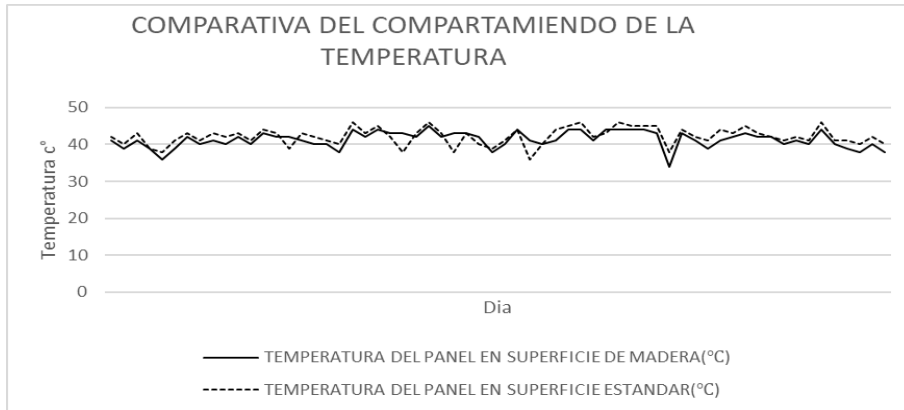

Source: own.

Relating the power, it can be seen that the peaks are higher at 5:00 pm. The peak power was 12.4 W, for the wood and Drywall surface panel, while the lowest amount of power supplied was 0.7 W for the Standard surface panel, shown in figure 11.

Figure 11. Comparison of generated electrical power (Data collected at 12:00 m)

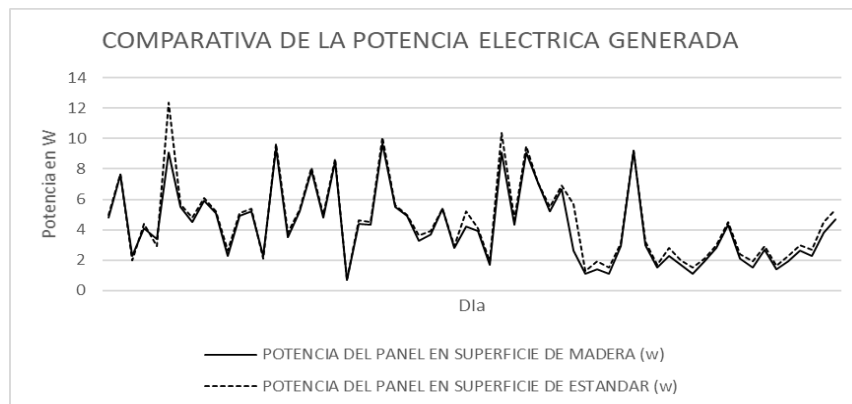

Source: own.

5. Conclusions

In the development of this research work, it was determined through the characterization and analysis of the electrical variables of the two photovoltaic panels that there were variations of these variables due to the temperature present in both surfaces, where the standard surface supplies more temperature than the wood and drywall surface in the 3 schedules, this can be evidenced by the graphs of average temperatures of the two panels where the standard surface panel obtained 9.17% more temperature at 8:00 am, 5.5% more temperature at 12:00 am and 2.22% more temperature at 5:00 pm than the panel on wood and drywall surface:00 am, 5.5% more temperature at 12:00 m and 2.22% more temperature at 5:00 pm than the panel on wood and drywall surface. Based on the above, it was determined that the wood and drywall surface has a higher absorption coefficient and a lower heat reflection coefficient than the standard surface (concrete).

Through the statistical interpretation of the comparative graphs, it was determined that the voltage supplied by the standard surface panel was higher than the wood and drywall surface panel in the 3 schedules, where it is evidenced by the comparative graph of averages that the standard surface panel obtained 3.01% more voltage at 8:00 am, 2.65% more voltage at 12:00 m and 2.11% more voltage at 5:00 pm than the wood and drywall surface panel.

With the statistical interpretation of the current variable, it was determined that the wood and drywall surface panel supplied more current than the standard surface panel during the 3 schedules, evidenced by the comparative graph of the average of this variable, where the wood and drywall surface panel obtained 15% more current at 8:00 am, 13% more current at 12:00 m and 8.04% more current at 5:00 pm than the standard surface panel.

In relation to the electrical power variable, it was determined through the interpretation of the average comparative graph that the wood and drywall surface panel supplied more electrical

power than the standard surface panel, that is to say that the wood and drywall surface panel was more efficient than the standard surface panel in the 3 schedules, where the wood and drywall surface panel obtained 12.64% more power at 8:00 am, 10.42% more power at 12:00 m, and 7.57% more power at 5:00 pm than the standard surface panel.

References

- [1] Cambio Energetico, “¿cómo influye la temperatura en el rendimiento de tu placa solar?”, 2017. [Online]. Available: <https://www.cambioenergetico.com/blog/influye-la-temperatura-rendimiento-placa-solar/>
- [2] Google Maps, “Google Maps”, 2019. [Online]. Available: <https://www.google.com/maps/place/Technological+Units+Santander/@4.4605312,-72.1018114,5z/data=!4m5!3m4!1s0x8e683fc8a8b0973f:0x5f50c91e41f0ac6e!8m2!3d7.105114!4d-73.1235999>
- [3] Alcaldía de Bucaramanga, “Santander”, 2017. [Online]. Available: <http://versionantigua.bucaramanga.gov.co/Contenido.aspx?Param=9>
- [4] Alcaldía de Bucaramanga, “Bucaramanga”, 2015. [Online]. Available: <https://www.bucaramanga.gov.co/el-mapa/division-politico-urbana/>
- [5] J. E. Vera, “Maximum power point tracking (MPPT) in solar panels”, Vision Electronica, vol. 8, no. 2, pp. 49-53, 2014.
- [6] S. Medina-Rincón, “Energías renovables un futuro óptimo para Colombia”, Punto de Vista, vol. 9, no. 13, 2018.
- [7] Y. E. García-Vera, “Comparative Analysis of the Performance of Monocrystalline and Polycrystalline PV modules in wheater conditions of Fusagasugá”, Ingenieria, vol. 24, no. 1, 2019.
- [8] I. Bonilla-Camposa, “Energy efficiency assessment: Process modelling and waste heat recovery analysis”, Energy Conversion and Management, vol. 196, p. 1108, 2019.
- [9] A. C. Valencia, “Crisis energética”, Universidad Distrital, pp. 74-81, 2016.