



UNIVERSIDAD DISTRITAL
FRANCISCO JOSÉ DE CALDAS

Visión Electrónica

<https://doi.org/10.14483/issn.2248-4728>





VISIÓN ELECTRÓNICA

A RESEARCH VISION

Enterprise Architecture fundamental axis for IT transformation to meet the challenges proposed by Covid-19 in Colombia

Arquitectura Empresarial eje fundamental para transformación de TI para enfrentar los retos propuestos por Covid-19 en Colombia

Roberto Ferro-Escobar ¹, Héctor Albeiro Dussan-Montoya ², Kevin David Garzón-Quintero ³

INFORMACIÓN DEL ARTÍCULO

Historia del artículo:

Enviado: 30/10/2021

Recibido: 08/11/2021

Aceptado: 18/03/2022

Keywords:

CPI

Enterprise Architecture

Inflation

Remote Access

SMEs

Virtual Innovation

Virtual Management



Palabras clave:

IPC

Arquitectura Empresarial

Inflación

Acceso Remoto

PYMES

Innovación virtual

Gestión virtual

ABSTRACT

This article aims to show the advantages of implementing an Enterprise Architecture model and each of its phases within the organizations in Colombia that must be digitally transformed, in addition to showing a vision for the migration of certain work activities to the field of virtuality. It is also important to highlight the alignment of business objectives to the implementation of the Enterprise Architecture model, showing characteristics, advantages and limitations in terms of logistics when establishing monitoring and control strategies in the identification of the most vulnerable population to contract COVID-19, which has shown a stronger devastating aspect in the second wave than in the first one.

RESUMEN

Este artículo pretende mostrar las ventajas de implementar un modelo de Arquitectura Empresarial y cada una de sus fases dentro de las organizaciones en Colombia que deben ser transformadas digitalmente, además de mostrar una visión para la migración de ciertas actividades laborales al campo de la virtualidad. También es importante destacar la alineación de los objetivos de negocio a la implementación del modelo de Arquitectura Empresarial, evidenciando características, ventajas y limitantes en materia de logística a la hora de establecer estrategias de monitoreo y control en la identificación de la población más vulnerable a contraer el COVID-19 que ha mostrado un aspecto devastador más fuerte en la segunda ola que en la primera.

¹PhD. in Computer Engineering, Universidad Pontificia de Salamanca, Spain. MSc. in Teleinformatics, Universidad Distrital Francisco José de Caldas, Colombia. E-mail: rferro@udistrital.edu.co

²BSc. In Industrial Engineering, Universidad Distrital Francisco José de Caldas, Colombia.

³BSc. In Industrial Engineering, Universidad Distrital Francisco José de Caldas, Colombia. E-mail: kdgarzonq@correo.udistrital.edu.co

1. Introduction

This document is an analysis that shows the importance and the need to rethink the business models of Colombian companies using IT “Information Technology”, allowing the migration of processes and services to the virtual field as financial, commercial and educational activities among others.

This period of pandemic has generated a massive challenge worldwide, therefore, methodologies and good business practices must be established to promote the implementation and use of information technologies articulated in the Enterprise Architecture and aligned with the business objectives of existing companies in Colombia, which mostly correspond to the classification of SMEs and MSMEs.

According to DANE “Departamento Administrativo Nacional de Estadística” (National Administrative Department of Statistics), micro, small and medium-sized companies in Colombia represent around 80% of the employment in the country and 90% of the national productive sector, most of them being directly affected by the decrease in productive activity as a consequence of the beginning of the mandatory isolation from March 23, 2020 until April 13, 2020, extending in the first instance until April 27 of the same year, a challenge for the companies since they have not designed contingency plans that will enable them to face such an abrupt change [1].

The need to implement an Enterprise Architecture model is of vital importance for any organization, it facilitates the transformation of its activities without losing any alignment with its business objectives, which at present must be adjusted to a virtual model. Colombia is currently leading the implementation of the Enterprise Architecture under the leadership of the MINTIC, who has established regulations for national organizations to follow its guidelines and can perform a transformation of their business under the guidance of the ministry. The framework of concern for the country is to prevent the national economy is affected and therefore not suffer a slowdown causing an increase in certain indicators such as inflation, CPI, which in turn increase the cost of resources for daily use.

The management that the government has developed since the beginning of the mandatory isolation has been concentrated in the creation of an application called CoronApp where a parameterized management is made

with the information of symptoms and alarm signs reported and geo-referenced by citizens, the government can have a national overview in real time on the generation of symptoms and specific locations that may be cause for alarm about the spread of the virus. In this application, the data provided to the app are monitored in real time by the Emergency Operations Center of the National Health Institute, who with this information will be able to act quickly and provide support in coordination with local departmental and national authorities. With data on their health status, entities can anticipate actions, strengthen their understanding of the virus, better manage possible cases of Coronavirus and alert, when necessary, through notifications via text to specific groups of the population, articulating with the 123-emergency line.

2. Enterprise architecture

2.1. Definition of AE

It is a strategic practice that consists of comprehensively analyzing the entities from different perspectives or dimensions, with the purpose of obtaining, diagnosing, and evaluating their current state and establishing the necessary transformation that allows them to evolve from the current state to the target business architecture. The objective is to generate value through Information Technologies to facilitate the fulfillment of the mission objectives of the institution and the sector or territory to which they belong, generating benefits to the business or organization. An architecture is broken down into several structures or dimensions to facilitate its study. For the Framework of Reference established for the Colombian State, the Enterprise Architecture is made up of two major elements: The business or missional architecture and the IT architecture. This integration of elements should be understood as the way to align the different components of the entity from the strategy, processes, plans, programs, projects and people, with the components of the IT architecture, represented in the 6 domains of: IT Strategy, IT Governance, Information, Information Systems, Technological Services and Use and Appropriation, so that, together, they maximize their contribution to the institutional objectives and consequently their contribution to the country is greater [2].

It is important to define key stages in the implementation of any type of Enterprise Architecture,

which must be oriented to the direction of the business objective. For the case of Colombia, the MINTIC developed an organizational architecture framework consisting of a Business Architecture and IT Architecture, with the idea of integrating the business model, the mission, strategic management and the modeling of processes and procedures within organizations through the implementation of technology by performing an analysis of the importance within the company's being, evaluating which aspects of technology should be improved, eliminated or implemented, with the idea of fulfilling and satisfying the strategic objectives of the organization.

The Enterprise Architecture is developed through a cycle of continuous improvement, i.e. the changes made are carried out gradually, taking the company from an initial situation identified in the diagnosis (as-is) to a future situation (to-be) parameterized within the EA Reference Framework.

2.2. Benefits of implementing Enterprise Architecture, Figure 1.

- Enterprise Architecture enables the alignment of organizational processes and elements connected to IT systems through a strategic plan.
- It directs all resources to the fulfillment of the organizations' business objectives by ensuring that all projects are aligned with the company's policies and principles to meet the needs of the business.
- Promotes the reduction of company performance costs related to IT operation, support and upgrades, reducing the risk of all IT-related projects.
- The company's strategic vision is better developed by being managed through the role of ICT to support business processes being achieved in a more efficient way.
- It allows the organization to adapt in a more agile way to the accelerated changes of the environment and new technologies, to improve response times and organizational growth.
- It minimizes the duality of tasks and responsibilities since it establishes a framework in which the hierarchical scope of collaborators and stakeholders is determined.
- Improves decision making within organizations as it orients in an organized manner the interest of satisfaction and fulfillment of business objectives.

- Changes can be made gradually according to business need from the current business model guided by the framework through a cycle of continuous improvement.

Figure 1. Benefits of Enterprise Architecture aligned with IT (MINTIC)



3. Enterprise architecture and business objectives

3.1. Frame of reference

National and territorial entities should understand and adopt the Reference Framework for IT management in Colombia (MINTIC), to facilitate the process, it is recommended that entities follow the following four steps:

- 1. Preparation:** For this step it is necessary to understand the context of the frame of reference, in order to make a diagnosis against the framework that serves to prepare the organization and its action plan.
- 2. Strategy for Enterprise Architecture (EA) exercises:** This step indicates how the EA exercises will cover the needs of the company, defining the current technological situation of the company, efficiently determining the IT capacity to be improved and/or implemented.
- 3. Definition of an EA exercise:** it is important to plan the Enterprise Architecture (EA) exercise in detail, defining the need, scope, resources,

required equipment, results, organizational coverage, project governance, timeframe and schedule for each activity consolidated in a deliverable for the organization.

4. **Execution of the EA exercise:** The previous steps allow defining the current situation (As - Is) of the company to project the target situation (To - Be) to which the company aims, in point it is possible to know how much is the gap to move from one situation to another, that is to say, how far we are from the target, this evaluation allows formulating the roadmap that the company must follow.

It is worth noting that these steps can be repeated through a cycle of continuous improvement that allows adjustments according to the need and technological development, allowing not only that organizations modify their business model but also that they can adapt to the environment through the use of IT in this sense, making processes and services more flexible through its use, being a transformer and developer of conventional work, facilitating the transition from face-to-face work to virtual work for many activities.

3.2. How to align business objectives with Enterprise Architecture?

It is important to know that the Enterprise Architecture establishes a description of the company's strategic management, it breaks down a detailed characterization of the company, its functional and operational structure. This allows integration parameters to be established according to what the company requires in its operation; it is essential to highlight which areas of the organization are efficiently structured, which ones present opportunities for improvement and which ones should be replaced. Having a clear vision of what we want to do, now a question arises about how to align these objectives previously described to the Enterprise Architecture, because for this we must be clear about what the Enterprise Architecture offers us and it is a systematic vision, a continuous improvement establishing an integral evaluation of all the impacts that can generate the changes, modifications or essential replacements of important aspects for the business objectives of the company.

Enterprise Architecture enables or facilitates business intelligence, which is a key factor for the good

Figure 2. Articulation of EC with its associated elements [3].

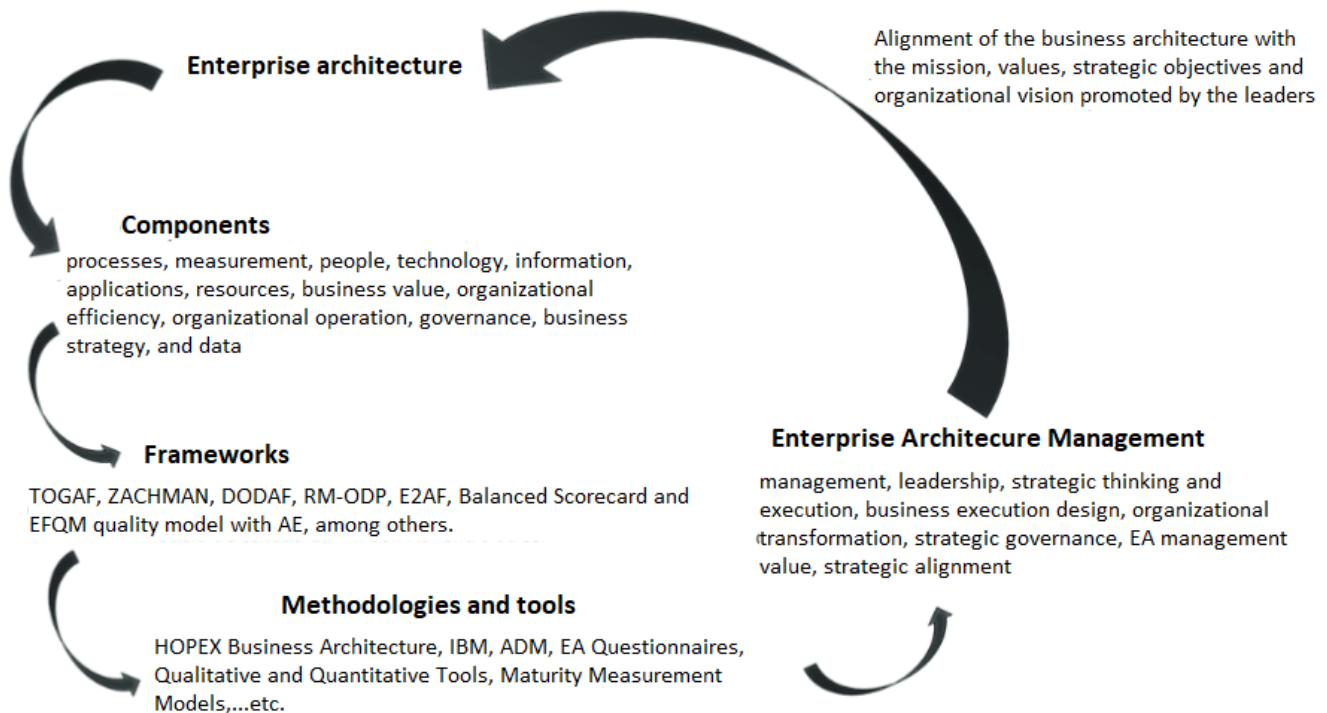

use of organizational technology, where organizations can consider the use of an Enterprise Architecture, specifically the service-oriented one, to integrate business intelligence (BI) with operational systems, with prior identification of the need. An important alternative is to develop a good management oriented to the articulation of information technologies, systematically integrating processes, methods and tools in order to develop a frame of reference adjusted to the technological capacity of the company that allows it to satisfy all the business needs that will allow it to be competitive in the high demands of its environment.

Next, we can see how Mr. Gonzalez in his article on the design of a proposal for the definition of the Enterprise Architecture, states different aspects involved in the characterization and modeling of a frame of reference necessary to dimension the main needs for the satisfaction of the business objectives adjacent to the organization, Figure 2.

It must be clear that Enterprise Architecture comprises a number of relevant aspects such as data, information, processes, applications, technology and the human factor, essential to establish measurements through the creation of indicators to assess the level of compliance, organizational effectiveness and strategic structuring aimed at developing an adequate strategic execution that involves the alignment of organizational values, strategic objectives, organizational mission and vision. With all this we can say that the treatment of information contributes to the creation of knowledge that allows the continuous improvement of processes using applications and technology. All this being managed by the human factor, which favors to greatly improve the decision making within the company, complying with the established times for the achievement of the established objectives.

3.3. The Need to Implement EC in Times of Pandemic

The Enterprise Architecture provides a comprehensive strategy that ensures alignment of the business mission and vision set forth by the company's leaders, with the clear understanding that it will serve as an architectural support as the company evolves and achieves its objectives. Thus, the Enterprise Architecture includes tangible and intangible components that delimit the vision, mission, business strategy, governance, IT, data and organizational information.

In addition to this we can affirm that Enterprise Architecture has a scope that includes SMEs that in the case of Colombia cover almost 80% of the organizations, which are being negatively affected with the cessation of the economy because of the pandemic originated in Wuhan, China. In spite of what happened, no organization in our country established in its risk matrix a possible affectation of these characteristics; however the Enterprise Architecture has a wide field of application that allows to be incorporated in any type of organization, regardless of the economic sector to which it belongs, so that the diagnostic measures and tools used for the management of the Enterprise Architecture vary according to the organizational characteristics, but its starting point is general and very similar.

It is not unknown that the Colombian people have suffered negative impacts in the economy, education, health, productive area, and the financial field, this followed by the lack of a controlling entity that objectively involves all the different resources that make possible an excellent management, restructuring and migration of some economic sectors through a remotely virtual participation.

There has been developing prior to the announcement of the preventive isolation where the MINTIC in its version 2.2 of October 2019 updates the Digital Government guidelines, which had articulated since 2016. This compilation of policies and guidelines mostly invites SMEs to review the frame of reference and align their business objectives with the Enterprise Architecture, which has a high impact on the continuous improvement of processes and decrease of time in terms of compliance and achievement of objectives [4]. This requires human, financial and technological resources that in the long term will show the advantages of having implemented this framework; however, it is advisable to perform the migration in small projects to achieve early victories and strengthen the confidence of senior management with these processes [2].

In recent weeks some organizations have chosen to develop alternatives that allow them to continue developing their business activities through teleworking while continuing to offer their services to different customers. Although this strategy is essential, some organizations do not have a repository for information storage, most of the human factor does not have the technological capacity at home to assume the service provision, in some cases there is no compatibility or

proper configuration because the network service provider differs depending on the area where the task is performed.

The highly impacted sectors that require labor, such as the productive sector, are limited in the implementation of EC, since the use of the technological factor is limited, and the number of workers that allow the harvesting of the crop for internal distribution to the different consumers has been reduced with respect to the confinement measures. However, government measures have established strategies that do not allow the economy to stagnate.

The good management of the Enterprise Architecture will allow to have a broader vision at the time of making precise and punctual decisions when required, for which it is clearly necessary to have at hand a structured corporate policy and governance that allows to articulate a good management of the information technologies, fundamental to give a management, access and assurance of the knowledge generated within an organization. Regarding the management of compulsory confinement, the analysis of the growth of the contagion curve, analysis of the population vulnerable to contagion and mortality from infection; the government has created web portals to offer help to the vulnerable population that lacks health services and food supplies. In addition, it has collaborated with the expansion of national communiqués, so that the community is clear on how to act in the face of the risks of displacement in this time of isolation. Currently, the country is facing an imminent digitalization of processes as they become increasingly complex, which makes it strictly necessary to have an Enterprise Architecture model, since different technologies coexist, which must be linked to business policies increasingly complex in terms of capacity and coverage.

In the last decade the digitization process has accelerated too much in the public sector, but short-term solutions have been taken, where a problem is identified and a way to manage it now is developed, but it is not thought in a synergic way, where the State does not see enough importance to increase the capacity of information systems, information technologies and their distribution channels. For this reason, it is of vital importance that government institutions design a present architectural model and project a future model that allows them to achieve the initially designed objectives, thus allowing a synchronization with the

digitalization process of their processes, cost reduction, implementation of congruent initiatives and sizing of projects associated with the strategic plan of the government entity.

4. Gap analysis

The government currently does not have a contingency plan in place to mitigate the advance of the contagion curve, since it was initially unaware of the impact of the beginning of the pandemic in China, it should be noted that for every day that the international airport EL DORADO remained open, the number of COVID-19 infected cases increased exponentially, This was reflected in a conflict of interest between keeping the normal flow of passengers afloat without any type of biosecurity control, which is evidence of poor management and an imminent need to implement Enterprise Architecture.

According to the segmentation of confirmed cases of COVID-19 worldwide, Table 1, we can see which countries took immediate measures and mitigated the spread of the virus, in Table 2, we can see some of the countries that refused to take restrictive measures to protect the population against the spread of the virus.

Countries such as the USA, Italy and Spain had an exponential and abysmal increase in the number of cases infected with the virus because the governments did not take the corresponding measures due to a lack of knowledge of how to proceed in the face of this problem; however, it must be made clear that there is also a cultural component, since the population that meets the demands of the government in these cases can keep out of the contagion and help to ensure that the infection curve does not exceed the capacity of the health system of each affected country. Acting late in this type of situation entails health problems since it requires the necessary resources to identify possible cases of infection, preventive quarantines, isolation of confirmed cases, medical equipment, human resources, development of vaccines and drugs for the treatment of the affected population. In spite of this, there are governments that have acted in time and have identified the main sources of infection and immediately restricted them. The following are the countries that currently have one of the lowest rates of COVID-19 infection

Table 1. World Ranking, Countries with the highest number of COVID-19 cases [5]

N°	Country	Cases
1	USA	856.209
2	Spain	213.024
3	Italy	189.973
4	France	157.135
5	Germany	151.285
6	United Kingdom	139.246
7	Turkey	101.790
8	Iran	87.026
9	China	83.878
10	Russia	62.773
11	Brazil	46.701
12	Belgium	42.797
13	Canada	42.560
14	Netherlands	35.921
15	Switzerland	28.496
16	Portugal	22.353
17	India	21.797
18	Peru	20.914
19	Sweden	16.755
20	Ireland	16.671

Table 2. World Ranking, Countries with lowest COVID-19 cases [5]

N°	Country	Cases
86	Guinea	862
87	Cyprus	795
88	Latvia	778
89	Andorra	723
90	Diamond Princess	712
91	Lebanon	688
92	Costa Rica	681
93	Bolivia	672
94	Albania	663
95	Niger	662
96	Kyrgyzstan	631
97	Burkina Faso	609
98	Uruguay	549
99	Honduras	519
100	Kosovo	510
101	San Marino	501
102	West Bank and Gaza	480
103	Senegal	479
104	Malta	445
105	Jordan	437
106	Taiwan*	427

When making a contrast between the two positions, the question arises: What influences a nation to be more efficient than another in terms of decision making and preventive action? This must do to a greater extent with the governmental structuring that is oriented to the implementation of the Enterprise Architecture and the use of information technologies that allow any state to adapt quickly to any type of problem that it faces at any given time, in this case the threat of a pandemic. To give a more real approach to our country, it is important to

establish the “AS IS” that it faces today and that it would lack to implement and articulate to the governmental and systematic management because in this way all types of problems could be dealt with regardless of their nature.

As we can see in Table 2, countries such as Taiwan, Malta and Jordan present a low number of infected by COVID-19, due to timely implemented strategies such as immediate reduction of flights, creation of central commands for epidemic control. Taiwan established

different government and investigative agencies since the last SARS pandemic where it has been on the lookout for possible outbreaks of cases. All this due to tracking systems where they can determine the places visited by the infected and make projections and statistical analysis on the possible cases and the speed of spread. But how is all this possible, is very simple to answer, information technology, technological capacity and synchronization of government agencies in dealing with a problem. In this way, it was possible for this country of less than 26 million inhabitants to control the spread of the virus.

In the case of Colombia, it is important to discuss certain deeper aspects that make it difficult to make investments in government sectors such as science and technology, education and health, areas that are extremely important for a nation to have the tools to face major problems such as the one we are currently experiencing. One of the most important aspects is the socio-cultural component, where the citizenship will attend to the measures established only when

protection policies are offered to comply with possible quarantines, isolation of infected people and generalized isolation. One initiative that the country could include in its government policies would be to raise from 0.2% to 1.5% of GDP, as stated by the World Bank in its investment policies (“Research and development expenditure (% of GDP) [6].

Next, annual GDP growth by supply for the second quarter of 2018 will be contrasted with that of 2019, Figure 3:

According to DANE data, the communications sector had a growth of 4.2%, which shows that this sector is being encouraged; unfortunately, it is not enough and the country needs to establish modifications in the government plan, since it would bring many benefits for the strengthening of a sector that is facing a digital transformation. If the necessary resources are not gathered to start such an initiative, the country could become less competitive with other nations in the region.

Figure 3. Annual GDP growth 2019 vs. GDP 2018 expressed as a percentage [7]

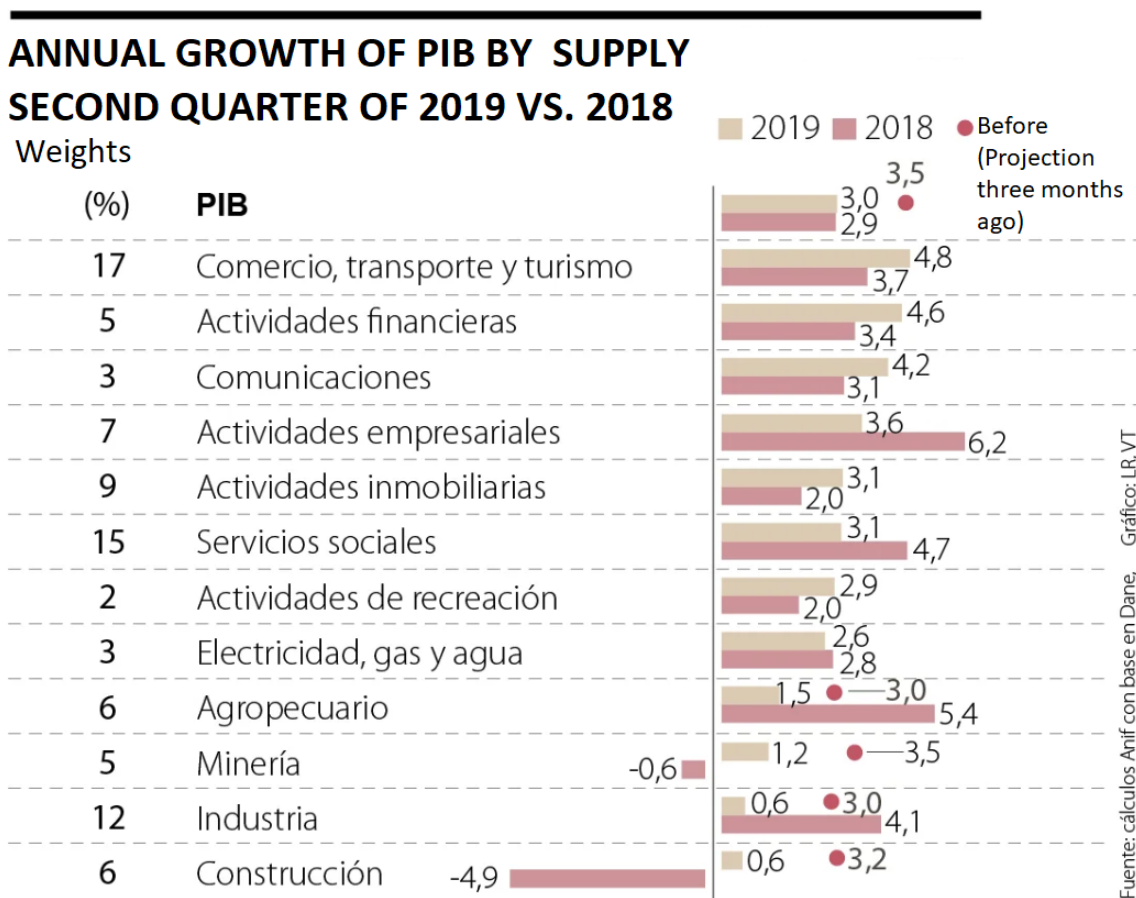

In summary, with respect to the aforementioned, Colombia must structure its information technologies focusing on creating information systems that have a capacity, according to governmental activities, where it must manage the creation of investigative teams oriented to monitor and follow up the current impacts of this pandemic and other future ones, which seek to mitigate to a greater extent the increase of cases; for this it is important to incorporate in its government structure the Enterprise Architecture linked to the strengthening of ICT.

For Colombia to be able to face a subsequent pandemic in an agile and efficient manner, it must be clear that its control entities must be systematically articulated to act in a timely manner in the event of the appearance of infected cases, suggesting preventive isolation and social isolation. A particular case in the national territory was the lack of interest to act immediately before the sanitary crisis, since questions arose such as: Why was not the EL DORADO airport closed as soon as it was known about the expansion of the cases of infection in European countries, how many passengers transit daily and where do they come from? These two questions could have helped to identify what measures to take in the face of the threat of infection; however, there are governmental interests that did not allow to take action on the matter, due to threats of economic deceleration, which was the highest priority before protecting citizens.

According to the latest update of the Aero civil portal, in Colombia transited between departures and arrivals about 75,556,950 in 2019 of which 34,975,000 correspond to passenger traffic of El DORADO about 46.29% of the total. To evaluate the impact of closing EL DORADO immediately we could say that the air operation would be immediately reduced by half because in simpler terms 95,821 passengers would be transiting daily, mostly coming from domestic traffic and international traffic from destinations such as Madrid, a major hub between Eastern Europe and America, Miami and Germany. These figures suggest that the delay in taking a premature decision to suspend aeronautical activities would directly affect this sector, which is why it was necessary to avoid the indefinite closure of the national airport hubs. These lessons learned will allow to identify the need to implement a systematic government in which the citizenship is established in an inclusive manner, projecting the long-term impact of initiating any measure in the face of this type of eventuality.

5. Logistical problems for the implementation of AE

5.1. Development of APPs for COVID-19 monitoring and management.

As soon as the identification of the first COVID-19 infected person was announced on March 7, approximately, the Government proposed the creation of a free application where citizens could download it from their cell phones to solve a simple test about the symptoms they could develop daily if they develop a high-risk activity and high exposure to the SARS-2 virus. Currently, more than 2 million users have registered through CORONAPP who have.

The company has collaborated with the daily report of their condition, in addition to including their family nucleus and the identification of possible cases that may be around them.

5.2. Information

This portal provides a very detailed explanation of how to manage all the relevant information about the COVID-19 virus. In addition to all this, it should be noted that the National Institute of Health, the Ministry of Health and the MinTIC joined forces for the development of this application which, despite being a great advance to mitigate the expansion of cases, falls short because there are factors of coverage, capacity and knowledge on the part of the population that hinder the full socialization of this technological tool to the entire Colombian population. An important factor to take into account is that not the entire Colombian population has access to the Internet, and even fewer have a mobile device, laptop or desktop computer, Figure 4.

Figure 4. CoronApp [8].



It is important to identify opportunities for improvement in terms of the impact of poor management of data collection, since a precarious identification of infected cases can help to measure an unrealistic growth of the infection curve, the number of active cases, and deaths due to this disease, where the segmentation of information will make it possible to make decisions far removed from the real impact of this eventuality.

Faced with this problem, a systematic management model must be established to guide decision-making based on the tools of good leadership, including the public and providing good resource management through a strategic design that allows for the effective collection of all the information concerning this type of eventualities that are currently occurring; However, in order to carry out this initiative, the country must

identify the limitations that prevent the development and establishment of the Systematic Management model, for this purpose, Figure 5 shows the relationship between each of the stakeholders to establish the scope of responsibility between each of the instances.

All this must be commanded under the concept of governance, which is key to obtain an institutional transformation in which the different actors are efficiently articulated, through a strategic framework that leads to stimulate economic growth with social inclusion, among which we find the State, the market and civil society. By achieving a good articulation, a transformation and growth can be achieved in different fields that allow establishing the best performance of the systematic model.

Figure 5. Management Model Diagram [9].

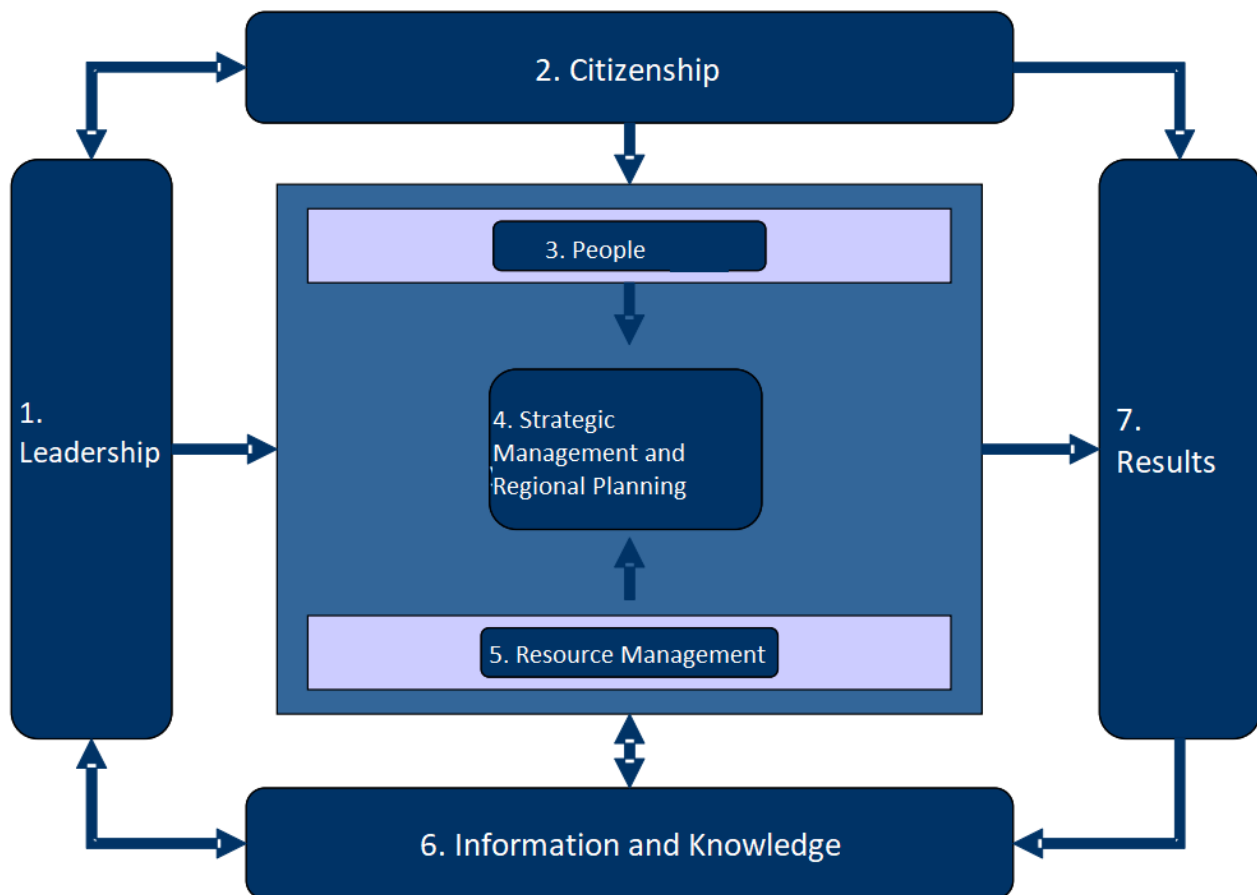

5.3. Opportunities for improvement in the management of ICTs

- As a first step, Colombia must ensure that the entire population has access to the Internet.
- That the technological infrastructure allows a constant use of the network where low-income citizens can benefit.
- Design of strategies where the entire population is included in the use of ICTs in their daily activities.

According to ICT Minister *Sylvia Constaín* in an interview given on October 28, 2018, mentions the following clarification:

“The technology and communications sector is advancing by leaps and bounds in the world, but in Colombia it seems to be going backwards more and more. If there is no way to connect to cyberspace, to which companies, governments, cars, hospitals, and almost everything that exists today are connected, artificial intelligence, ‘big data’, or new entertainment services like Netflix will be of no use.” [10]

Although the implementation of fiber optics is encouraged in all strata, 20% of stratum 1 has direct access and stratum 6 is around 99.8%.

5.4. Population at risk of contracting COVID-19

In reference to the implementation of Enterprise Architecture, many studies converge in that one of the main problems is the resistance to change, this is a challenge for stakeholders to consider changing their business model around IT, this resistance to change can be propitiated by different causes such as:

- Lack of knowledge and training in IT tools.
- There is no evidence of the need for implementation.
- We do not want to leave the comfort zone in which the company is located.
- Involves large investments and/or related expenses
- No time and/or disposition available.

In the meantime, the Colombian Government must ensure that the measures taken respond in an agile manner to curb the exponential growth of infected people, through strategies that involve the citizenry by

providing self-care guidelines to reduce the probability of acquiring the disease.

More causes may be related and even others associated with resistance to change may be present at the same time, it's important to generate scenarios where more information can be provided about Enterprise Architecture and the MINTIC Framework of Reference, incentives for its application and the benefits of its implementation can be identified.

Colombia in the last two decades has made significant investments in infrastructure and information technologies, according to the PND (2012 - 2020) the resources projected for investment until 2020 will reach \$112 billion. This figure 6 would be divided into the sectors of housing, city and territorial development (\$16.6 billion, 15% of the total), investment in information and communication technologies (ICT, \$9.9 billion, 9%), urban transportation (\$8.4 billion, 8%), mines and energy (\$13.7 billion, 12%) and transportation (\$63.7 billion, 57%).

Figure 6. Infrastructure Investment [11]

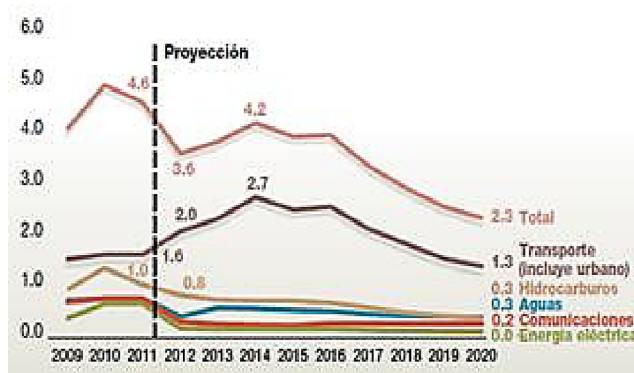

On the other hand, the PND (2018 - 2022) in its goal 16 plans to double public and private investment in science and technology to 1.5% of GDP [10], when analyzing the projections of investment in infrastructure from 2009 to 2020 and comparing it with the PND of the current presidency Iván Duque 2018 to 2022, an increase in investment for communications of 1.3% of GDP is evident.

As a proposal within the most opportune implementations of Organizational Architecture, the government led by the president should be included in the decision-making process, Figure 7.

Figure 7. Modified version of Motivational view diagram derived from the need to generate an enterprise architecture model related to the topic of scientific publications [12].

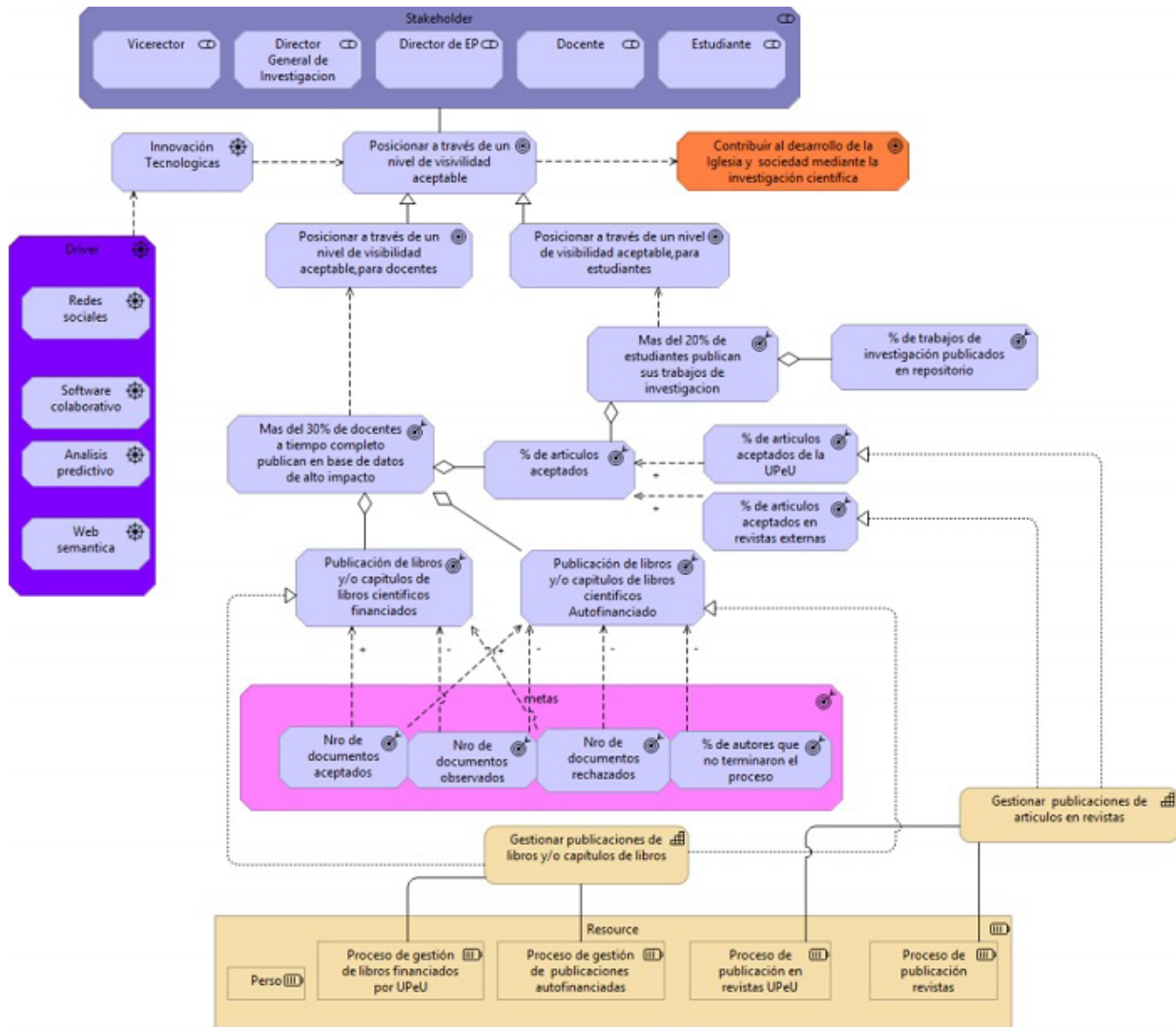
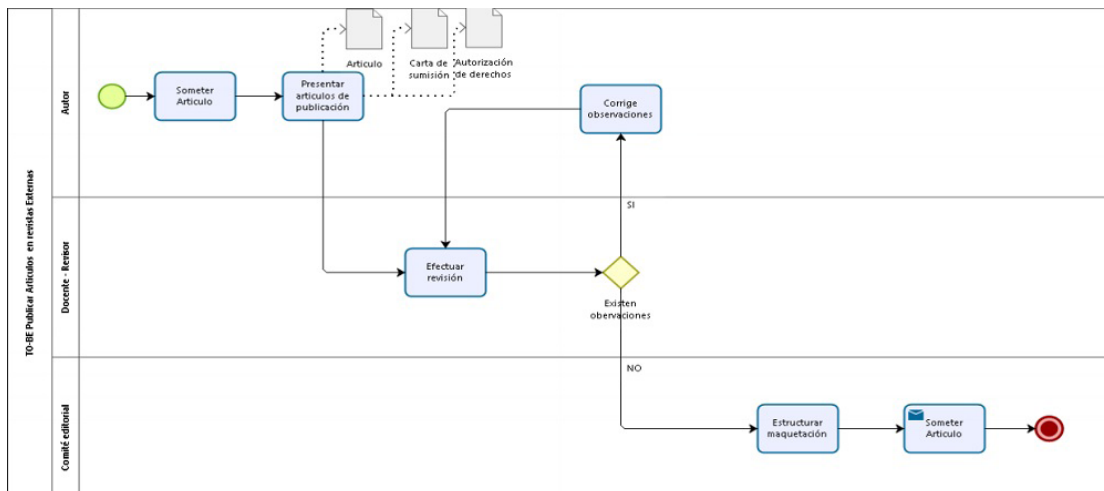

Figure 8. Modified version of Proposed To-Be Model [12].



Institutions and citizens must also be involved in the implementation of these activities. To this end, a model of integration between stakeholders and systematic government is proposed, each time knowledge is to be produced [13], Figure 8.

6. Conclusions

It is necessary for companies to adopt more flexible business models, which articulate with Information and Communication Technologies due to the constant change of the market as a result of its dynamics and externalities such as COVID-19, it is observed that companies have been able to continue working thanks to the developments of large Internet companies such as Amazon, Google, Microsoft and Cisco that allow using their applications and developments so that people can communicate, share documents and achieve business objectives, some small companies have had crises because they do not have a digital transformation model. Although there is evidence of an increase in investment in the communications sector “projected vs. current”, Colombia still has to make more efforts to invest not only in this sector of “Communications” but also in innovation and development generating further study and research leading to a better use of ICT in the business field, thanks to the Enterprise Architecture and its phases is possible to perform gap analysis to move from a state As-Is to a To-Be, where the digital transformation is performed taking into account all aspects that are required.

The Enterprise Architecture is a methodological guide that allows the articulation of not only the business processes of a company but also the new processes related to the mitigation and reduction of possible cases of virus infection, providing the organization with appropriate communication channels to meet the challenges it brings with it, this in turn allows the adaptation and flexibility of business processes in terms of IT and virtualization of the same.

References

- [1] DANE, “Presupuesto y estados financieros”, 2020. [online]. Available: <https://www.dane.gov.co/index.php/servicios-al-ciudadano/tramites/transparencia-y-acceso-a-la-informacion-publica/presupuesto-general-asignado#presupuesto-general>
- [2] Ministerio de Tecnologías de la Información y las Comunicaciones, “Guía General de un Proceso de Arquitectura Empresarial”, pp. 1–41, 2016. [online]. Available: http://www.mintic.gov.co/arquiturati/630/articles-9435_Guia_Proceso.pdf
- [3] C. H. González Campo, J. Lozano Oviedo, “Propuesta para la definición de la arquitectura empresarial”, *Dimensión Empresarial*, vol. 18, no. 1, 2020. [https://doi.org/10.15665/dem.v18i\(1\).2109](https://doi.org/10.15665/dem.v18i(1).2109)
- [4] F. G. Palacios-Urgilés, M. A. Campoverde-Molina, “Análisis de la arquitectura empresarial como oportunidad de mejora en las microempresas de la ciudad de Cuenca”, *Dominio de Las Ciencias*, vol. 5, no. 3, 2019. <https://doi.org/10.23857/dc.v5i3.949>
- [5] Arcgis, “Dashboard Coronavirus COVID-19”, 2020. [online]. Available: <https://www.arcgis.com/apps/opsdashboard/index.html#/85320e2ea5424dfaa75ae62e5c06e61>
- [6] Banco mundial, “Gasto en investigación y desarrollo (% del PIB)”, 2020. [online]. Available: https://datos.bancomundial.org/indicador/GB.XPD.RSDV.GD.ZS?name_desc=false&view=map
- [7] Larepublica, “PIB-real segundo trimestre de 2019 y revisión de pronósticos”, 2020. [online]. Available: <https://www.larepublica.co/analisis/sergio-clavijo-500041/pib-real-segundo-trimestre-de-2019-y-revision-de-pronosticos-2900103>
- [8] Rumble, “CoronApp: La aplicación para que conocer la evolución del coronavirus”. [online]. Available: <https://rumble.com/embed/ubedx.v6hok3/?rel=0>
- [9] Rimisp, “Guía para el proceso de autoevaluación con el modelo de gobernanza territorial, identificación de fortalezas, áreas de mejora y diseño del plan de mejoras”, 2013. [online]. Available: https://www.rimisp.org/wp-content/files_mf/1399575508GuiaGenerica_ModeloGenerico.pdf
- [10] Presidencia de Colombia, “Bases del Plan Nacional de Desarrollo”, 2018. <https://id.presidencia.gov.co/especiales/190523-PlanNacionalDesarrollo/documentos/BasesPND2018-2022.pdf>

- [11] S. Clavijo, A. Vera, “La inversión en infraestructura en Colombia 2012-20: Efectos fiscales y requerimientos financieros”, pp. 7-14, 2013.
- [12] N. Saboya, O. Loaiza, D. Lévano, “Diseño de un modelo de arquitectura empresarial para publicaciones científicas basado en adm - Togaf 9.0”, 2018. [online]. Available: <https://www.redalyc.org/jatsRepo/4676/467655911004/html/index.html>
- [13] H. Dussan, K. Garzón, “Diagnóstico para la creación de un modelo bajo la arquitectura organizacional TOGAF aplicado en las dependencias TIC de la Universidad Distrital Francisco José de Caldas”, pp. 1–126, 2017.