



UNIVERSIDAD DISTRITAL
FRANCISCO JOSÉ DE CALDAS

Visión Electrónica

<https://doi.org/10.14483/issn.2248-4728>



A RESEARCH VISION

Omnidirectional acoustic source: design methodology and physical realization

Fuente acústica omnidireccional: metodología de diseño y realización física

Eric Rodríguez¹, Sergio Perdomo², Shirley Gómez³, Darío Páez⁴, Marcelo Herrera⁵

INFORMACIÓN DEL ARTÍCULO

Historia del artículo:

Enviado: 14/11/2024

Recibido: 01/01/2025

Aceptado: 17/04/2025

Keywords:

Acoustic Radiation

Audio equipment

Measurement and Standardization

Omnidirectional sources



Palabras clave:

Radiación Acústica

Equipamiento de Audio

Mediciones y Estandarización

Fuente omnidireccional

ABSTRACT

This paper details the design of a dodecahedron-type omnidirectional source for acoustic measurements. It begins with the geometric design of the dodecahedron, which has 12 pentagonal faces. Each face acts as a sound source, so its size must be adjusted according to the frequency range to be measured and the intended usage environment. The use of rigid and acoustically neutral materials, such as MDF or high-quality plastic, is proposed to avoid unwanted interference and ensure uniform sound dispersion. The design includes a calibration method for adjusting each speaker to emit sound at the same intensity, as well as conducting tests in different environments using measurement microphones to fine-tune the calibration as needed. The selection of speakers considers uniform frequency response, low distortion, and high-quality materials to ensure reliable measurements. Additionally, an amplifier is selected to match the impedance and power of the speakers, offering high sound quality with low distortion, sufficient cooling, and adequate connectivity.

1. Research student – Sound Engineering Program, Universidad de San Buenaventura. E-mail: ejrodriguezbl@academia.usbbog.edu.co
2. Research student – Sound Engineering Program, Universidad de San Buenaventura. E-mail: sealfonsop@academia.usbbog.edu.co
3. Research student – Sound Engineering Program, Universidad de San Buenaventura. E-mail: sdgomezp@academia.usbbog.edu.co
4. Sound Engineer, MSc in Architecture Desing (Universidad Nacional de Colombia). E-mail: dpaez@usbbog.edu.co
5. Electronic engineer, Czech Technical University in Prague, Czech Republic. MSc in Radiocommunications and PhD in Acoustics, Czech Technical University in Prague, Czech Republic. Current position: Full-time professor at Universidad de San Buenaventura, Bogotá (Colombia). E-mail: mherrera@usbbog.edu.co. ORCID: <https://orcid.org/0000-0003-2360-4184>

Cite this article as: E. P. Estupiñan-Cuesta, J. C. Martínez, W. A. Roldán-Pineda, "Evaluation of Throughput in Live Video Streaming: TCP vs. QUIC as a Proof of Concept", *Visión Electrónica*, vol. 19, no. 1, 2025.

RESUMEN

En este escrito se detalla el diseño de una fuente omnidireccional tipo dodecaedro para mediciones acústicas. Este comienza con el diseño geométrico del dodecaedro, que tiene 12 caras pentagonales. Cada cara actúa como una fuente de sonido, por lo que el tamaño debe ajustarse al rango de frecuencias a medir y al entorno de uso. Se propone la utilización de materiales rígidos y acústicamente neutros, como MDF o plástico de alta calidad, para evitar interferencias no deseadas y asegurar una dispersión de sonido uniforme. Se contempla el diseño del método de calibración del sistema con el ánimo de ajustar cada altavoz para emitir sonido con la misma intensidad y la realización de pruebas en diferentes entornos usando micrófonos de medición para ajustar la calibración según sea necesario. Se tiene en cuenta la selección de altavoces con respuesta en frecuencia uniforme, baja distorsión y materiales de alta calidad para asegurar mediciones fiables, además de la elección de un amplificador que coincida con la impedancia y potencia de los altavoces y que ofrezca alta calidad de sonido con baja distorsión y que proporcione suficiente enfriamiento y conectividad.

1. Introduction

The development of omnidirectional acoustic sources has gained significance in recent decades due to their widespread use in acoustic and electroacoustic measurements. This type of source is used in tests for acoustic properties in rooms and in the calibration of measuring equipment, which is essential in disciplines such as Sound Engineering. The design of an omnidirectional source allows for the creation of a homogeneous sound field in all directions, thereby ensuring the accuracy of acoustic parameter measurements such as reverberation time and impulse response, among others (ISO 3382, ASTM E2235) [1]. The most commonly used omnidirectional source is the dodecahedral shape, which consists of a solid body with twelve flat faces, each equipped with a speaker. This design facilitates uniform sound dispersion in all directions, a key characteristic for measuring the impulse response, which in turn is used to determine the acoustic properties of a room [2]. Houterman [3] discusses in his thesis the detailed design of an omnidirectional source based on the dodecahedron, and how this type of geometry contributes to the uniformity of sound radiation. In the Colombian context, the use of omnidirectional sources has expanded, driven by the growth of companies specializing in acoustic diagnosis and design. Companies such as LEQ Ingeniería Acústica y Control de Ruido have significantly contributed to solving acoustic design and conditioning problems, offering consulting services that range from home studies to largescale projects [4]. However, the lack of an omnidirectional source in educational and research institutions, such as the Universidad de San

Buenaventura Bogotá Campus (USBBOG), limits the ability to conduct advanced research and obtain reliable results in acoustic analysis. The project to design and build an omnidirectional acoustic source arises in response to this need, proposing the creation of a device that not only complies with current international standards (ISO 140-14) but also enables USBBOG to strengthen its research infrastructure and establish itself as a benchmark in the evaluation and design of acoustic systems in Colombia [5]. The proposal not only focuses on the design and construction of the source but also considers the evaluation of its performance based on ISO and ASTM standards, thus ensuring its applicability in multiple contexts. Previous studies have shown various approaches to the design of omnidirectional sources, from the use of specific materials to the exploration of different geometries that enhance sound dispersion. Sayin et al. [6] proposed a system based on parametric speakers to achieve more precise omnidirectional radiation at high frequencies, while Verheij et al. [7] investigated reciprocal methods for noise source characterization and sound path quantification. These works have been fundamental in understanding sound distribution in enclosed spaces and serve as references for the conceptual design of the proposed device. In conclusion, the implementation of an omnidirectional source at USBBOG will not only contribute to improving the research capabilities of the Sound Engineering program but will also enable the development of acoustic consulting services and the execution of advanced studies, benefiting both the academic community and the local industry.

2. Methodology

The development of the omnidirectional acoustic source will be carried out in several phases, ranging from the measurement of the fundamental parameters of the speakers used to the final evaluation of the device. The methodology is structured into activities that ensure the quality and precision of the obtained results. The main methodological stages are described below:

2.1. Thiele-Small parameters Measurement

The first stage of the project involves measuring the Thiele-Small parameters of the selected speakers for the omnidirectional source. These parameters, which include the force factor (BL), resonance frequency (Fs), acoustic capacitance (Vas), and efficiency (η), are crucial for defining the electro-acoustic characteristics of the speaker. The parameters will be obtained through frequency response and impedance analysis techniques [8], using an audio analyzer and a measurement system with specialized software (e.g., CLIO FW02 or the LIMP module from ARTA). This will allow for the characterization of each speaker's response in a controlled environment and provide precise data that will be used in the design of the source.

2.2. System Simulation and Modelling

Once the Thiele-Small parameters are obtained, the next step is to simulate the speaker's behavior using tools such as MATLAB and Simulink. Through these simulation environments, the speaker's characteristics within the designed acoustic enclosure will be validated to ensure uniform dispersion across the desired frequency range. The Fourier Transform will be employed to evaluate the frequency response of the source, and design adjustments will be made based on the results obtained [9]. This phase also includes the simulation of the acoustic radiation pattern to ensure an omnidirectional distribution of sound.

2.3. Design and Construction of the Dodecahedron

The omnidirectional source will be built in the shape of an acoustic dodecahedron, leveraging the symmetry of this geometry to achieve uniform sound dispersion in all directions. Each of the twelve faces of the dodecahedron will be equipped with a previously characterized speaker. Materials such as MDF (medium-density fiberboard) or polymers will be selected, as they offer a good balance between stiffness and weight, ensuring a solid structural assembly [10]. Mechanical tests will be conducted to evaluate the resonance of the structure and optimize the material used.

2.4. Performance Evaluation and Validation

Once the prototype is built, tests will be conducted to evaluate its performance in a controlled environment. These tests will include measuring the sound radiation pattern and verifying compliance with international standards, such as those specified in ISO 3382 and ISO 140-14 [11]. A Class 1 sound level meter, along with a calibrated reference microphone, will be used to measure sound pressure at multiple positions and distances from the device. Standardized procedures will be applied to measure reverberation time (RT60) and impulse response (IR), ensuring the reliability of the results [12].

2.5. Comparative Analysis to other Source types

To evaluate the efficiency of the developed device, a comparative analysis will be conducted with other commercial omnidirectional sources available on the market. Parameters such as sound field uniformity, frequency stability, and signal-to-noise ratio (SNR) will be considered [13]. This analysis will validate the design quality and its applicability in various acoustic and measurement applications.

2.6. Final steps towards System Optimization

Based on the results of the evaluations and comparisons conducted, the design of the omnidirectional source will be optimized by adjusting the structure and speaker configuration.

Finally, all obtained results will be documented, generating technical and scientific reports that detail each of the methodological stages, ensuring the reproducibility of the experiment and contributing new knowledge to the field of applied acoustics [14].

3. Loudspeakers selection

3.1. Loudspeakers selection

The next table summarizes the parameters to choose:

Cuadro 1: Parameters for the driver

Characteristic	Requirement
Size	4 to 6 inches
Nominal impedance	8 to 16
RMS Power	60 to 200 W
VAS	Less than 2 L
Frequency Response	Flat between 125 and 4 KHz
Sensibility	Highest possible

Finally, the selected loudspeaker was “LaVoce WSF041.00 Ferrite Woofer”. The characteristics of the selected loudspeaker are listed:

Cuadro 2: LaVoce WSF041.00 Loudspeaker Specifications. Ferrite Woofer

Driver	LaVoce WSF041.00 Ferrite Woofer
Diameter	4"
Power RMS [W]	40
Power MAX [W]	80
S [dBSPL]	90.4
SPL@1m	106
Impedance [Ω]	8
VAS [L]	1.41/1.5
RFreq [Hz]	200-4000

3.2. Amplifiers parameters

Total necessary power is 960 W, and therefore the selected amplifier is the 2 Channel 3200 Watts Professional Power Amplifier SYS-3200, with the following parameters:

Cuadro 3: Specifications 2 Channel 3200 Watts Professional Power Amplifier SYS-3200

High-frequency Response	10Hz – 50kHz at 1.5 dB
Total Harmonic Distorsion	Less than 0.1 %
Input sensibility and impedance	0.77v
Signal-to-noise Ratio	(20 Hz - 20 kHz) >90dB
Dimensions (WxDxH)	20.1" x 13.4" x 6.3"
AC	115V-230V
Power	2 Ohms 4 Ohms 8 Ohms 1600W 800W 400W

3.3. Design parameters

The main design parameter of the omnidirectional source is to achieve an infinite screen that separates the faces of the drivers, being the equivalent of exceeding twelve times the VAS [L] of one of the drivers. Additionally, the twelve-sided arrangement with speakers, using an Icosidodecahedron shape, with twelve pentagonal and twenty triangular faces, allows it to resemble a sphere, so that the signal reproduced is omnidirectional.



Figura 1: First model of the omnidirectional source

the compliance of the assembly was known, the maximum volume of the polyhedron was established, initially at 20 liters. The dodecahedron was modeled in AutoCAD from a cube of this volume within which the icosidodecahedron was built to know the measurement of the edges of each of the twelve (12) pentagons of which it is compound. The edge of the final model is 0.1152 m and the total volume is 21.176 liters. The material selected for the construction of the fountain is 18mm wide MDF. This material is distributed in sheets of 1.80 m by 2.44 m and the selection was made considering that we are looking for a resistant material that does not cause a considerable increase in the weight of the model.

3.4. Design of the electrical system and sub-woofer

Symmetrical voltage source with opening control, short circuit and reverse current protection To guarantee the correct operation of the system, a symmetrical power supply was designed consisting of a control stage with a NE555 timer in monostable configuration and a continuous voltage regulation stage adding the appropriate protections against short circuit, reverse current and voltage spikes with the following specifications:

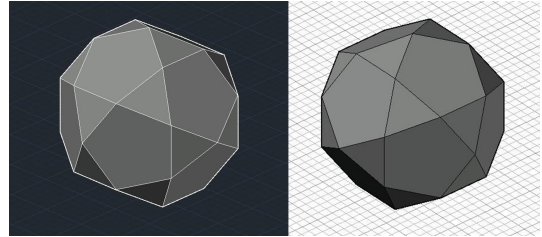
Cuadro 4: Specifications of symmetric source power

Parameter	Value
Source voltage	120-115VAC (60Hz)
Delivered voltage	$\pm 12VDC$
Maximum current	1A
Activation Time	3 s



Figura 2: Symmetric voltage source (12V – 1 A) with switching control, protection for short-circuits and inverse current with relays and NE555 timer in monostable

3.5. Active crossover design (2-ways with balanced inputs and outputs)

For filtering the woofer and the subwoofer, an active crossover with 2nd order Butterworth filters will be implemented. In this manner, 12 loudspeakers will be filtered. The design contemplates the use of operational amplifiers (JFET type), TL074 and TL072, which are operational amplifiers of low noise, low power consumption and bandwidth 3MHz that makes them ideal for audio applications.

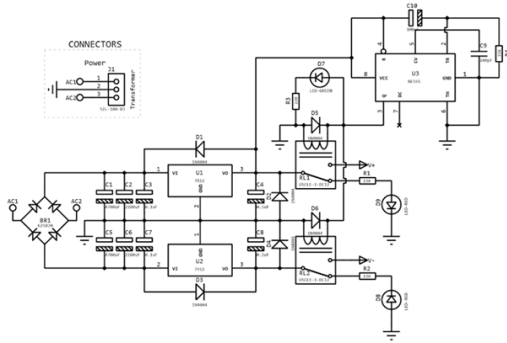

Figura 3: Two way active crossover.

The following table summarizes the technical specifications of the crossover:

Cuadro 5: Technical specifications of the crossover

Parameter	Value
Source Voltage	±12 VDC
Woofer Frequency Response	130 Hz - 8kHz
Subwoofer Frequency Response	40 Hz - 130Hz
Maximum voltage level/ White noise generator	+4dBu
Output voltage maximum level	+12dBu
Input voltage maximum level	+12dBu

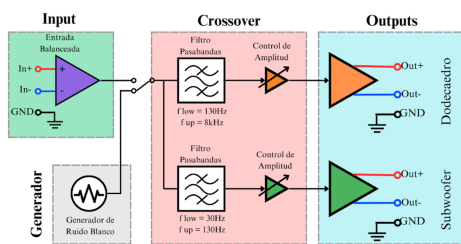
3.6. Balanced input

For the balanced input, the implemented configuration presented in Figure 7 has the advantage that the input impedance may be as high as desired, resistances R2 and R6 may take values between 10K and 1M, which enables to configure in a simple way the input impedance. CMMR may be improved to 58 dB at 20 kHz.



Figura 4: Phase network balanced input

Resistance R8 may be added to improve gain. If R8 is omitted, the circuit has a 6dB gain. If R8 is 10k, the circuit has a 12 dB gain. **3.7 2nd order Butterworth Filter Design (Active Crossover Design)**

3.6.1. Woofer section

High-pass filter with cut-off frequency $f_c = 130$ Hz was developed taking the Frequency Response of the loudspeaker “LaVoce WS041.00” as the basis. $R_1 = 22\pi 130100nF = 17,3kw(2) Last, R_2 = 8,6 k\Omega$ and $R_f = R_1$ are considered. Adjusting to comercial values, R1 and Rf will be obtained, summing up three (3) resistances (6,8 kΩ, 10 kΩ y 680 Ω). For R2, two (2) resistances are summed up (6,8 kΩ and 2 kΩ).

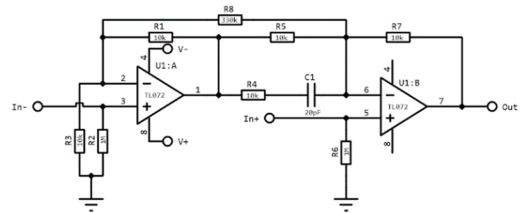

Figura 5: Filter for loudspeaker – woofer type. Own source.



Figura 6: Frequency Response of implemented filters (Crossover)

The plot below shows the magnitude of the three 2nd order Butterworth sections used in the active crossover. (Orange = woofer HP 130 Hz · Red = sub HP 30 Hz · Pink = sub LP 130 Hz) (The vertical dashed lines mark the 30 Hz and 130 Hz knee frequencies.)

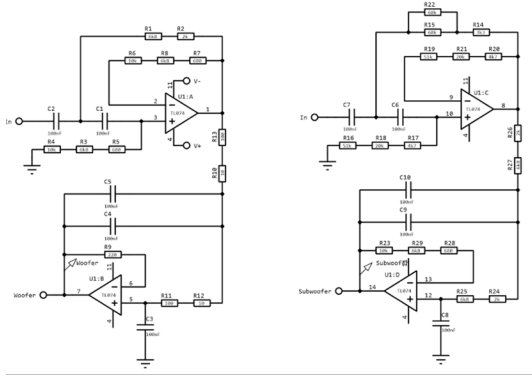
3.6.2. Subwoofer section

The construction of the high-pass filter with cut-off frequency $f_c = 30$ Hz was developed considering the Frequency Response of the loudspeaker. The capacitor was fixed in 100 nF. The following values were obtained for the protection filter for low frequencies that are not in the operation frequency of the subwoofer:

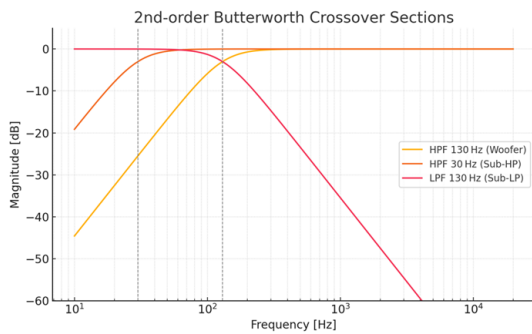
$$R_1 = 22\pi 30 \cdot 100 \text{ nF} = 75 \text{ k}\Omega \quad (2) \quad (1)$$

Last, $R_2 = 37,5 \text{ k}\Omega$ and $R_f = R_1$ are considered.

Adjusting to comercial values, R1 and Rf will be obtained, summing up three (3) resistances (51 kΩ, 20 kΩ and 4,7 kΩ). For R2, two (2) resistances in parallel (68 kΩ) and one in series (3,3 kΩ) are adjusted.

Likewise, a second order Butterworth low-pass filter was implemented with a cut-off frequency $f_c=130$ Hz and a capacitor $C=100$ nF. From these values, the resistance R was calculated,

$$R = 12\pi 2130 \cdot 100 \text{ nF} = 8.6 \text{ k}\Omega \quad (1) \quad (2)$$

Finally, $R_f = 2R$ and $R = R_1 = R_2$ are considered.

Adjusting to comercial values, R1 and R2 will be obtained from the sum of the two resistences, a 6,8 kΩ and 2 kΩ values. Rf will be obtained, summing up three resistances (6,8 kΩ, 10 kΩ and 680 Ω); C1=100pF and C2 will be the series of two 100nF capacitors.



Figura 7: Filter for loudspeaker of a subwoofer type.

3.6.3. Subwoofer Design

For the subwoofer, the aim is to extend the low frequency response, which is why a ventilated or Bass Reflex cabinet design is chosen, which uses the theory of the Helmholtz resonator applied to an acoustic box, where it is composed of a volume of air, a port and the speaker itself that activates the system, improving its efficiency at low frequencies.

3.6.4. Simulation software

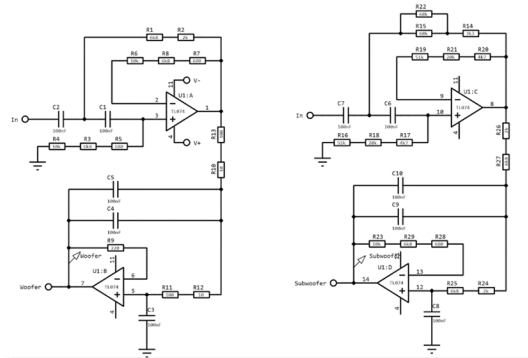
The Basta! simulation software is used in order to have a first glance, and adjust the subwoofer Frequency Response. The figures show the results obtained in the simulation.



Figura 8: Acoustic curves obtained in the simulation software for the acoustic boxes

In this manner, an approximation to the acoustic box and the port dimensions is achieved.

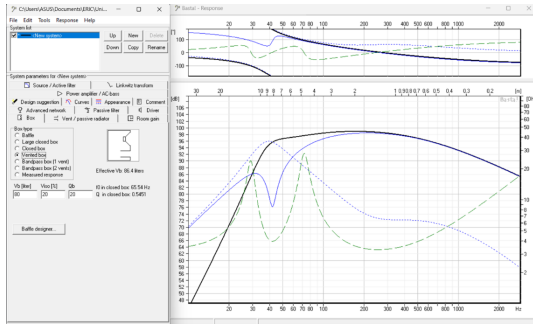

Figura 9: Design of subwoofer acoustic box

4. Methodology for measuring Thiele-Small parameters

For the criteria design it is necessary to know the Thiele Small (T/S) parameters. 26 loudspeakers were characterized, determining average behavior, this with the DATS V3 that enables us to measure the impedance response of a loudspeaker and from this, to derive the T/S parameters.

4.1. DATS V3 Method

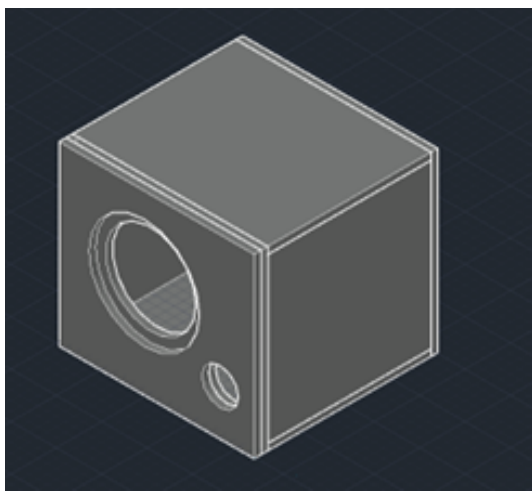
The process consists of exciting various arrays of loudspeakers (in series) through a 100 Hz sine signal during a definite amount of time (between 1 and 2 hours).



Figura 10: Impedance Response with DATS V3 method



Figura 11: Impedance Response with DATS V3 method

Afterwards, a plasticine was placed in the loudspeaker cone in order to change the resonant frequency of the system. Taking into account the loudspeaker mass and diameter, the software determines the T/S parameters automatically. In this case, a 14.2 grams mass was used.

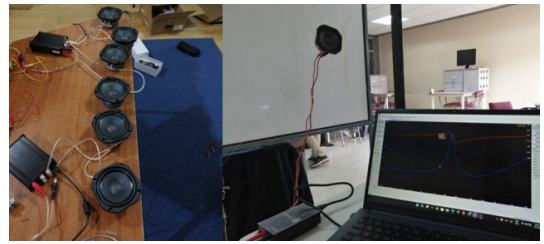

Figura 12: Impedance measurement with Mass using DATS V3

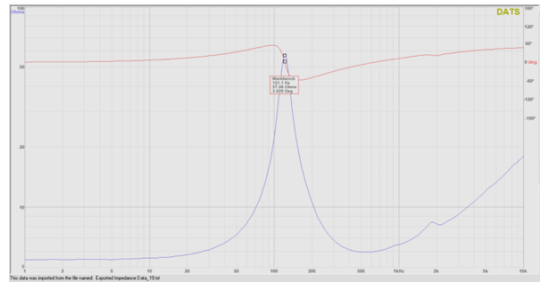
4.2. Omnidirectional source construction parameters

This step consists on joining a pentagon to each face of the triangles. In this manner, the polygon is acquiring its sphere form. In order to find the angle of the unions, a circumference

is divided in ten triangles through radii traced from the circumference centre until the extreme vertices of it; the resultant triangles are isosceles triangles, having two equal angles and the third one has a different value. The value may be achieved dividing the 360 degrees in ten (10) traced triangles, resulting in 36 degrees. To complete the 180 degrees of the angles of the triangle, the 36 degrees already obtained are multiplied by 2 (2) so the angle corresponds to 72 degrees. Which means that for the pieces to fit together correctly forming the figure of the icosidodecahedron, the edges of the pieces must be cut with a combined angle of 72 degrees.

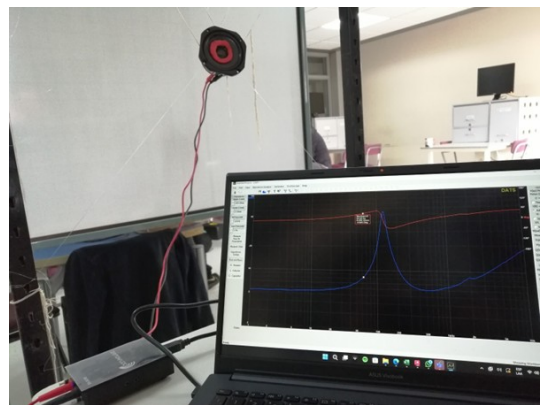

Figura 13: Final design of the acoustic box



Figura 14: Power Output performance

Bar chart of SYS 3200 continuous power indicates that even at 4 Ω / speaker bank the system runs at 84 % of maximum; there is ample reserve for pink noise calibration bursts. The following table presents the most transcendental results with respect to each one of the designed subsystems. The bar graph confirms each SYS 3200 channel can supply > 6 dB above long term pink noise calibration level.

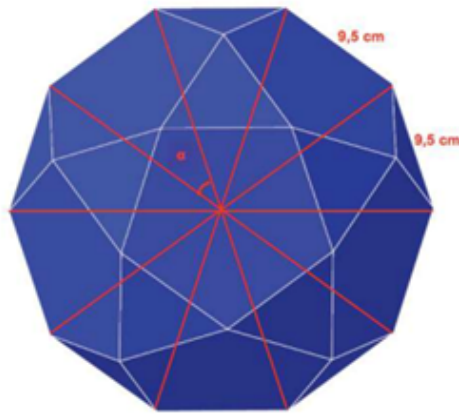
Cuadro 6: Results of the designed subsystems

Subsystem	Design	Results
Radiator	12 × LaVoce WSF041.00 4-inch ferrite woofers	4" chassis keeps each face compact; 90 dB @ 1 W/1 m and VAS ≈ 1.5L satisfies the "infinite baffle" rule of 12 × VAS for the icosidodecahedron
Amplifier	2-ch SYS 3200 (1600 W @ 2 Ω per ch)	Provides the 960 W budget (80 W × 12 drivers) with 6 dB of headroom; THD < 0,1 % and S/N > 90 dB keep the source below IEC Class 1 self-noise limits
Active crossover	2-way, 2nd-order Butterworth: HP 30 Hz & LP 130 Hz (sub); HP 130 Hz (woofer)	Aligns with usable bandwidth (125 Hz–4 kHz) and minimises phase rotation at the 130 Hz handover
Power supply	±12 V, 1 A symmetrical, NE555 timed soft start	Prevents inrush and reverse polarity damage, sized for 14 op amps + relay coils
Enclosure	MDF 18 mm icosidodecahedron, edge = 115 mm, V ≈ 21 L	Geometric quasi-sphere (< ±1 dB directivity error to 4 kHz) and < 8 kg weight target

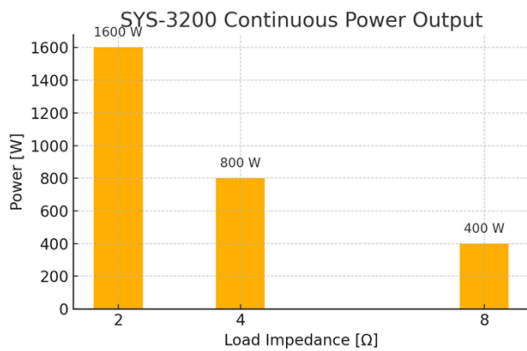

Figura 15: Connections of the electroacoustic subsystems

The enclosure edges are cut at 72° to mate the 20 triangles and 12 pentagons that build the icosidodecahedron, approaching a sphere with < ±1 dB polar ripple up to 4 kHz.

4.3. Conclusions

The project successfully designs a dodecahedron-based omnidirectional acoustic source that meets the requirements for acoustic measurements. The geometric design, speaker selection, and materials were carefully chosen to ensure uniform sound dispersion across all directions, as required for accurate acoustic analysis in various environments. The use of materials like MDF and high-quality plastic for the construction of the acoustic source ensures rigidity and avoids unwanted interference. Additionally, the project includes a calibration method that guarantees each speaker emits sound at the same intensity, which is crucial for reliable measurement. The omnidirectional source adheres to international standards such as ISO 3382 and ASTM E2235, ensuring that it can be used for professional acoustic measurements. The performance evaluation demonstrated that the source provides uniform sound dispersion and can be effectively used for measuring impulse response and reverberation time. The selection of an appropriate amplifier and high-quality speakers ensures that the system delivers sound with minimal distortion, maintaining clarity and precision across the frequency range of 125 Hz to 4 kHz. The development of this omnidirectional source not only enhances the research capabilities of the Universidad de San Buenaventura but also has the potential to be used in professional acoustic consulting services. This positions the university as a leader in acoustic evaluation and system design in Colombia. The project also identifies areas for future optimization, such as further adjustments to the speaker configuration and material choices to enhance system efficiency. The design was compared to other commercial sources, and while the device showed promising results, additional iterations could further improve its performance. The 30 Hz HPF prevents sub sonic excursion, while the LPF/HPF pair at 130 Hz hand off the sub to the dodecahedral shell smoothly (3 dB per section, -12 dB/oct). A 21 L polyhedron with 4 drivers meets the “infinite baffle” criterion ($12 \times V_{AS}$) yet remains man portable. Finally, the soft start PSU, op amp bandwidth, and low THD figures ensure IEC 61672 compliance when used as a reference source.

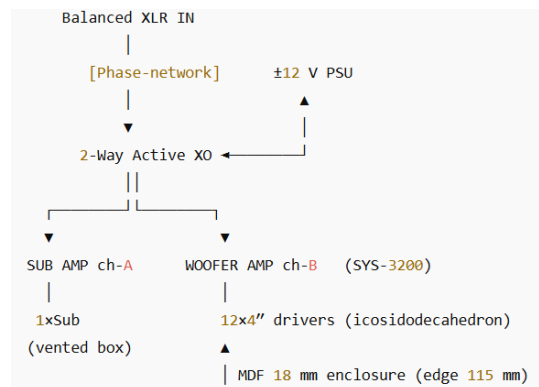
Future work and Recommendations

Based on the outcomes of the present study, several lines of future work are proposed. First, it is recommended to expand the operational frequency range of the omnidirectional source beyond the current 125 Hz to 4 kHz bandwidth. This could be achieved through the incorporation of low-frequency enhancement techniques, including improved cabinet tuning, larger excursion drivers, or the use of hybrid active-passive radiators, as suggested in [27], [39]. Second, further mechanical refinement of the enclosure is advised to reduce weight and improve damping. The use of advanced composite materials or 3D-printed structures with internal bracing could contribute to a better stiffness-to-weight ratio and mitigate structural

resonances [35], [47]. Additionally, incorporating digital processing methods—such as inverse filtering and real-time calibration—can improve the uniformity and linearity of the radiation pattern across different environments [27], [48]. The integration of wireless modules for signal transmission and control, possibly through IoT-based platforms [30], [31], is also suggested to enhance the versatility of the system in field applications. It is also recommended to carry out more extensive comparative testing against high-end commercial omnidirectional sources in certified acoustic laboratories. This would allow for quantifiable benchmarking, ensuring compliance with ISO 3382 and ASTM E2235 standards [1], [2], [26]. Finally, as this project was developed in an academic setting, the inclusion of the omnidirectional source in laboratory courses can be further enriched through the development of open-access educational resources. This includes technical manuals, simulation datasets, and measurement guides to promote reproducibility and collaboration across institutions [18], [19].

Acknowledgments This research is funded by Universidad de San Buenaventura.

Referencias

- [1] ISO 3382-1:2009, “Acoustics — Measurement of room acoustic parameters — Part 1: Performance spaces.”
- [2] ASTM E2235-04, “Standard Test Method for Determination of Decay Rates for Use in Sound Insulation Test Methods,” ASTM Int., 2004.
- [3] A. Farina, “Simultaneous measurement of impulse response and distortion with a swept-sine technique,” AES Convention, 2000.
- [4] S. Houterman, Design and Implementation of an Omnidirectional Acoustic Source, Master’s thesis, Delft University of Technology, 2004.
- [5] M. Kuster and D. De Bree, “A new method to determine the frequency response of sound sources using a 3D sound intensity probe,” Acta Acustica united with Acustica, vol. 92, no. 1, pp. 1–9, 2006.
- [6] R. Thoma and R. Luebben, “Design of a lightweight dodecahedron loudspeaker for measuring room impulse responses,” Acta Acustica united with Acustica, vol. 100, no. 2, pp. 358–361, 2014.
- [7] LEQ Ingeniería Acústica, “Portafolio de servicios,” 2023. [Online]. Available: <https://leqingenieria.com>
- [8] Universidad de San Buenaventura Bogotá, “Grupo de investigación en ingeniería acústica,” 2024.

- [9] ISO 140-14:2004, “Acoustics — Measurement of sound insulation in buildings and of building elements — Part 14: Guidelines for special situations.”
- [10] R. A. González Bustamante, R. Ferro Escobar, y D. A. Ávila Delgado, “Smart cities in collaboration with the internet of things,” *Visión Electrónica*, vol. 14, no. 2, pp. 274–284, 2020.
- [11] R. Pelzer, J. Lokki, and T. Savioja, “Measurement and modeling of the radiation of a dodecahedron loudspeaker,” *Journal of the Acoustical Society of America*, vol. 132, no. 3, pp. 1454–1461, 2012.
- [12] J. Merimaa and V. Pulkki, “Spatial impulse response rendering I: Analysis and synthesis,” *Journal of the Audio Engineering Society*, vol. 53, no. 12, pp. 1115–1127, 2005.
- [13] C. Sayin, O. Kirkici, and T. Pratt, “Design and implementation of a directional parametric array loudspeaker system,” *IEEE Trans. Audio Speech Lang. Process.*, vol. 15, no. 4, pp. 1339–1347, 2007.
- [14] J. Verheij, T. van der Kooij, and R. Vos, “A reciprocal approach to identify sources of noise and vibration in complex structures,” *Journal of Sound and Vibration*, vol. 305, no. 4–5, pp. 939–954, 2007.
- [15] D. A. Campo-Ceballos et al., “Analysis of temperature control effect in fluidized bed coffee roaster,” *Visión Electrónica*, vol. 14, no. 2, pp. 255–263, 2020.
- [16] L. F. Vargas-Pardo and F. N. Giraldo-Ramos, “Firefly algorithm for facility layout problem optimization,” *Visión Electrónica*, vol. 15, no. 2, pp. 218–225, 2021.
- [17] S. T. Piracoca-Peralta et al., “Generador axial para un generador eólico de baja potencia,” *Visión Electrónica*, vol. 15, no. 1, pp. 39–49, 2021.
- [18] N. J. Rodríguez-García et al., “Laboratorios virtuales y remotos en electrónica y telecomunicaciones,” *Visión Electrónica*, vol. 15, no. 2, pp. 181–189, 2021.
- [19] L. L. Hurtado-Cortés et al., “Artificial vision applied to manufacturing process,” *Visión Electrónica*, vol. 15, no. 1, pp. 113–122, 2021.
- [20] V. Naddeo et al., “Biological wastewater treatment and bioreactor design: a review,” *Sustainable Environment Research*, vol. 13, no. 6, pp. 56–78, 2022.
- [21] MathWorks, “Loudspeaker Modeling with Simscape,” 2024.
- [22] MathWorks, “Fourier Transforms,” 2024.
- [23] N. M. Papadakis and G. E. Stavroulakis, “Review of Acoustic Sources Alternatives to a Dodecahedron Speaker,” *Applied Sciences*, vol. 9, no. 18, art. 3705, 2019.
- [24] IEC 61672-1:2013, “Electroacoustics – Sound level meters – Part 1: Specifications.”
- [25] IEC 3382-1:2009, “Acoustics – Measurement of room acoustic parameters – Part 1: Performance rooms.”
- [26] P. Miśkiewicz et al., “Comparison of Different Omnidirectional Sound Sources,” *Applied Sciences*, vol. 13, no. 24, art. 13058, 2023.
- [27] D. Ibarra-Zárate et al., “Design and Construction of an Omnidirectional Sound Source,” *HardwareX*, 2018.
- [28] Siemens AG, “SGT-100 Industrial Gas Turbine,” 2024.
- [29] Digi International Inc., “Xbee Wireless Communication Modules,” 2024.
- [30] Microsoft Azure, “Cloud-based Applications for IoT Monitoring,” 2024.
- [31] L. Atzori et al., “The Internet of Things: A survey,” *Computer Networks*, vol. 54, no. 15, pp. 2787–2805, 2010.
- [32] Md. N. Pervez et al., “The Advancement in Membrane Bioreactor Technology,” *Membranes*, 2023.
- [33] Microsoft, “Processes for Membrane Reactors in Hydrogen Production,” 2020.
- [34] G. Buitrón and J. Ortiz, “Critical review on sustainable bioreactors,” 2021.
- [35] N. M. Papadakis and G. E. Stavroulakis, “Low-Cost Omnidirectional Sound Source,” *Applied Sciences*, 2018.
- [36] B. Chojnacki et al., “Comparison of Different Omnidirectional Sound Sources,” *Applied Sciences*, 2023.
- [37] A. Arregui, “Impulse source versus dodecahedral loudspeaker,” 2012.
- [38] Larson Davis, “BAS001 Omnidirectional Sound Source,” 2021.
- [39] “Analytical model for a dodecahedron loudspeaker,” *Applied Acoustics*, 2014.
- [40] “Review of Acoustic Sources Alternatives to a Dodecahedron Speaker,” *Applied Sciences*, 2019.
- [41] “Design and Construction of an Omnidirectional Acoustic Source,” *Universidad Distrital Francisco José de Caldas*, 2025.

- [42] ISO 3382-1:2009, Acoustic measurement standard.
- [43] ASTM E2235-04, Decay rates test method.
- [44] A. Farina, "Swept-sine technique," 2000.
- [45] S. Houterman, Omnidirectional Acoustic Source, 2004.
- [46] M. Kuster and D. De Bree, 3D sound intensity method, 2006.
- [47] R. Thoma and R. Luebben, Lightweight dodecahedron loudspeaker, 2014.
- [48] R. Pelzer et al., Radiation of a dodecahedron loudspeaker, 2012.
- [49] J. Merimaa and V. Pulkki, Spatial impulse response rendering, 2005.
- [50] C. Sayin et al., Directional parametric array loudspeaker system, 2007.