



UNIVERSIDAD DISTRITAL
FRANCISCO JOSE DE CALDAS

VISIÓN ELECTRÓNICA

Algo más que un estado sólido

<https://doi.org/10.14483/issn.2248-4728>



Evaluation of Li-Fi performance with Trulifi 6002: Connectivity validation using distance ranges

Evaluación del desempeño de Li-Fi con Trulifi 6002: validación de conectividad usando rangos de distancia

Edith Paola Estupiñan Cuesta¹, Juan Carlos Martínez Quintero², Jhon Stiven Gamboa Suarez³

Abstract

Li-Fi is an innovative technology that uses visible light to transmit data at high speeds. While it still faces some challenges, its potential to revolutionize wireless communications is undeniable. Unlike Wi-Fi, which uses radio waves to transmit data, Li-Fi leverages visible light, mainly emitted by light-emitting diodes (LEDs), to create a fast and secure communication medium. This work presents the results of an experimental study to evaluate the performance of Li-Fi technology using the Trulifi 6002 system in indoor environments. A Li-Fi network was implemented in a LAN environment evaluated in 3 scenarios with variations in luminosity and distance between the receiver and the transmitter. The objective was to validate the connectivity of the system at various distance ranges using the Trulifi6002

¹ Telecommunications Engineer, graduate of Universidad Militar Nueva Granada, Colombia. Master's in Electronic Engineering from Pontificia Universidad Javeriana, Colombia. Professor at Universidad Militar Nueva Granada, Bogotá, Colombia, in the Telecommunications Engineering Program. E-mail: edith.estupinan@unimilitar.edu.co ORCID: <https://orcid.org/0000-0002-4100-4943>

² Electronic Engineer, graduate of Universidad Manuela Beltrán, Colombia. Specialist in Physical and Computer Security, Escuela de Comunicaciones Militares, Colombia. Master's in Automatic Production Systems from Universidad Tecnológica de Pereira, Colombia. Professor at Universidad Militar Nueva Granada, in the Telecommunications Engineering Program. E-mail: juan.martinezq@unimilitar.edu.co ORCID: <https://orcid.org/0000-0001-9893-6592>

³ Telecommunications Engineer Student. Universidad Militar Nueva Granada, Bogotá, Colombia. E-mail: est.jhon.gamboa@unimilitar.edu.co

system. The implementation allowed for validating the system's connection and assessing how distance affects this stage of connection. Additionally, the advantages and limitations of Li-Fi technology are discussed, and recommendations for its implementation in real-world scenarios are proposed

Keywords: Indoor; ICMP; Network Communication; Li-Fi; RTT; Trulifi 6002.

Resumen

Li-Fi es una tecnología innovadora que utiliza la luz visible para transmitir datos a altas velocidades. Si bien aún enfrenta algunos desafíos, su potencial para revolucionar las comunicaciones inalámbricas es innegable. A diferencia de Wi-Fi, que utiliza ondas de radio para transmitir datos, Li-Fi aprovecha la luz visible, principalmente emitida por diodos emisores de luz (LED), para crear un medio de comunicación rápido y seguro. Este trabajo presenta los resultados de un estudio experimental para evaluar el desempeño de la tecnología Li-Fi utilizando el sistema Trulifi 6002 en entornos Indoor. Se implementó una red Li-Fi en un entorno LAN evaluada en 3 escenarios con variaciones de luminosidad y distancia entre el receptor y el emisor. El objetivo fue validar conectividad del sistema en varios rangos de distancia usando el sistema Trulifi6002. La implementación permito validar la conexión del sistema y como afecta la distancia en esta etapa de conexión; así mismo se discuten las ventajas y limitaciones de la tecnología Li-Fi y se proponen recomendaciones para su implementación en escenarios reales.

Palabras clave: Indoor; ICMP; Li-Fi; Redes de comunicaciones; RTT; Trulifi 6002.

1. Introducción

The exponential demand for wireless connectivity has driven the search for new technologies that overcome the limitations of Wi-Fi. In this context, Li-Fi (Light Fidelity) emerges as a promising alternative, leveraging visible light to transmit data at high speeds. Li-Fi, or Light Fidelity, is based on data transmission using the ability of LED diodes to

modulate their state and intensity at a speed imperceptible to the human eye. As a receiver, a photodetector converts the variations in the LED diode into a digital signal that is processed to decode the transmitted information [1][2].

VLC (Visible Light Communications) enables communication through visible light. The most common use of this technology is point-to-point links, where the propagation medium is the visible light spectrum. The transmitter source typically consists of one or more lights, such as LEDs, while the receiver is a photodiode responsible for detecting the transmitted light. VLC and Li-Fi technologies share features defined by the IEEE 802.15.7 protocol [3][4].

Li-Fi operates with a bandwidth that remains undivided, independent of the number of users. It can be used in locations where Wi-Fi is unsuitable due to its non-interference with radio frequency signals. This technology offers data transfer speeds ranging from 15 Mbps to 20 Gbps and, notably, provides both illumination and internet access, potentially contributing to energy savings [5][6].

Li-Fi does not use the radio frequency spectrum but rather the visible light spectrum, allowing it to avoid interference with radio frequencies and eliminating interference with devices connected to other wireless technologies. The spectrum used by Li-Fi is vastly broader than that of radio frequency communications, opening numerous possibilities for its application. This makes Li-Fi a viable alternative for addressing the saturation of the electromagnetic spectrum traditionally used, while also offering significant energy efficiency benefits [7].

One notable development in Li-Fi solutions comes from Signify, formerly known as Philips Lighting. As a global leader in lighting, Signify has made significant strides toward the future of wireless communications with its Trulifi technology. Signify's Trulifi 6002.1 is a high-speed Li-Fi communication system. Unlike Wi-Fi, which uses radio waves, Trulifi utilizes visible light to transmit data, transforming luminaires into data transmitters. Using LED light to send

information to compatible devices equipped with specialized receivers, Trulifi captures light and decodes it into usable data [8].

Some studies have explored various aspects of evaluating this technology. In [9], the performance analysis of Li-Fi is presented, focusing on different modulation techniques under various sources of ambient noise. A testbed was designed to analyze the technology's performance. In [10], a host-to-host connection using Li-Fi technology was implemented through VLC ports, with connection status verified using ping and the frequency used in the tests evaluated. An average ping time of 239,233 ms was achieved across 41 tests between transmitter and receiver, with successful connections maintained up to 70 cm in darkness despite variations in luminosity. In [11], an analysis of an indoor Li-Fi network is presented, evaluating its data transmission capacity for applications such as IoT. In [12], a theoretical description of Li-Fi technology is initially provided, followed by studies in the field and practical concepts for implementing Li-Fi-based networks using Trulifi 6002. The study highlights key performance metrics and important considerations for deploying such networks. In [13], a Li-Fi system for indoor audio transmission between transmitter and receiver is detailed. The system successfully transmitted audio for the proposed scenarios but noted limitations in bandwidth and the need for a direct line of sight to maintain the connection.

These prior studies reveal research focused on physical layer parameters such as modulation, bandwidth, and frequency for this type of technology. However, there is limited research analyzing the performance of Li-Fi networks at the indoor level, specifically evaluating performance metrics. Accordingly, this study evaluates a local network based on Li-Fi in an indoor environment, examining variations in distance and luminosity between the transmitter and receiver, and analyzing response times using the Trulifi 6002 system. The implementation validated the system's connection and assessed how distance impacts this

connection stage through ping tests, enabling the identification of the system's stability under real-world conditions by analyzing response times. Finally, this document is divided into three main chapters: the proposed scenario with a description of the tests, the implementation of the topology, and the results analysis.

2. Methodology

For this study, the methodology outlined in Figure 1 was defined. It consists of three phases for the execution of the activities in this research

Figure 1. Proposed Work Methodology

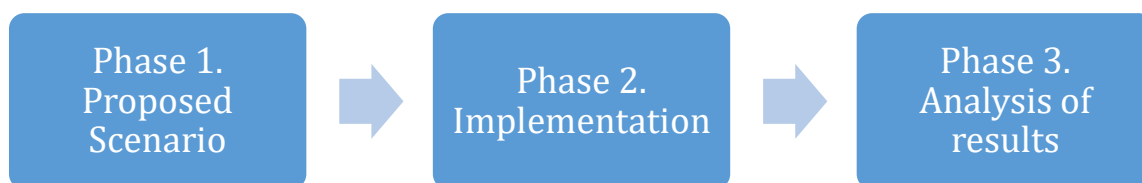

Source: Own work

- **Proposed Scenario:** This phase involves designing a Li-Fi topology using the Trulifi 6002 system for implementation. It also defines the tests to evaluate the connection effectiveness with varying distances.
- **Implementation:** In this phase, the two proposed topologies using the Trulifi 6002 system are implemented, and tests are conducted using ICMP.
- **Results Analysis:** This phase includes connection tests on the proposed topologies, followed by an analysis of the performance of the Trulifi 6002 system.

3. Development

3.1 Proposed Scenario

For the performance evaluation process of the Trulifi 6002 hardware, three test scenarios were defined. **Table 1** presents and describes the main elements used for these scenarios [14]. **Figure 2** shows the proposed scenarios. The objectives include measuring the system's performance as it moves away from the transmission point in environments with natural light, artificial light, and the absence of light.

Table 1. Technical characteristics of the equipment used

Equipment	Technical characteristics
Access Point Trulifi® 6002.1	System Power: 35W Voltage: 100-240 VAC Operation Temperature: +10°C +40°C Communication - RJ-12 and 45 / Fiber Optic Cable Encryption: Transceiver to Router AES-128
Trulifi® USB Key 6002.1	System Power: 3.5W Voltage: 5VDC Operating Temperature: +10°C +35°C Communication -PC USB 3.0 Type C Operating Systems Supported: Win7 and later-MacOS 10.14 and later Communication Type: Infrared
Infrared Transceiver Trulifi® 6002.1	System Power: 5W Voltage: 24VDC Supplied by Access Point Communication Type: Infrared Operating Temperature: +10°C +40°C Communication -Access Point Rj12 (7m) SFTP
PC	2 PCs HP -Windows
Switch	Switch CISCO – Ref. Catalyst 2950
Connectors and Cables	Transceiver STP RJ12 USB-C

Source: Own work

The Trulifi® Li-Fi Demo Kit allows height ranges from 1.20 m, an average of 1.80 m, to a maximum of 2.80 m, with a coverage radius of 1.50 m at the highest height. It is important to highlight that this technology operates on a Line-of-Sight (L.O.S.) basis, meaning that any obstruction or blocking of the light beam will immediately interrupt the communication, with the USB device's LED indicators signaling this disconnection. Additionally, this kit includes executable software that contains the Controller for Windows 7 and later operating systems, as well as MAC OS 14.0 and later versions [15]

Figure 2. Scenario Proposed

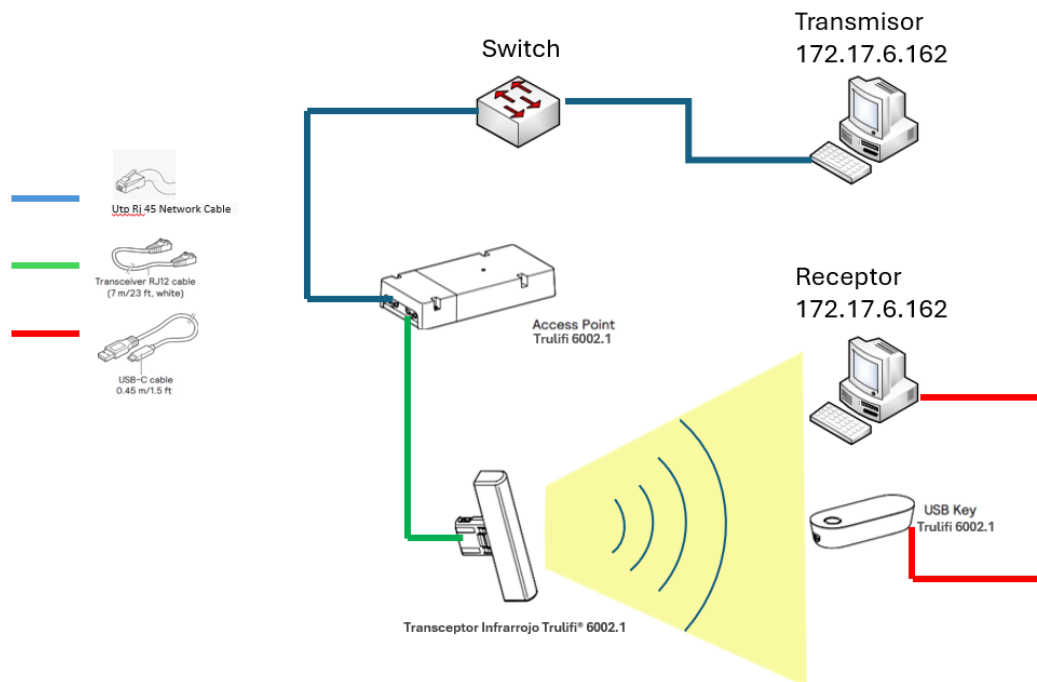

Source: Own work

3.2 Scenario implementation and test execution

Once the scenario is set in an indoor environment, three test environments are proposed: Natural Light Transmission, Artificial Light Transmission, and Transmission in the absence of light (darkness). According to the defined scenarios, the Figures 3 to 7 show the

implementation of the tests for indoor environments. ***The three scenarios are identified by the letters A, B, and C. Scenario A represents an indoor environment with natural light transmission, Scenario B is an indoor environment with artificial light transmission, and finally, Scenario C is the absence of light or darkness.*** Table 2 summarizes the data obtained in the three different scenarios, including values such as distance, average time, minimum time, maximum time, and the packet loss percentage. Regarding distance, different measurements were defined, with variations of 20 cm at each step, up to the maximum distance at which data could still be received. The end-to-end connection was validated using the ICMP protocol between hosts in the network. For this Trulifi 6002-based network, the receiver was configured with static IPs 172.16.6.162 and 172.16.6.163 for the transmitter.

In each test, 100 Ping packets were sent for all the defined measurements in the conditions of Scenarios A, B, and C. **Figure 3** illustrates the execution of the test at a distance of 40 cm, with views from different perspectives, both front-facing and from the Trulifi Transceiver 6002.1 located on the right side of the figure.

**Figure 3. ICMP-Trulifi 6002 Indoor connection tests, with distance of 40 cm.
Scenario A**

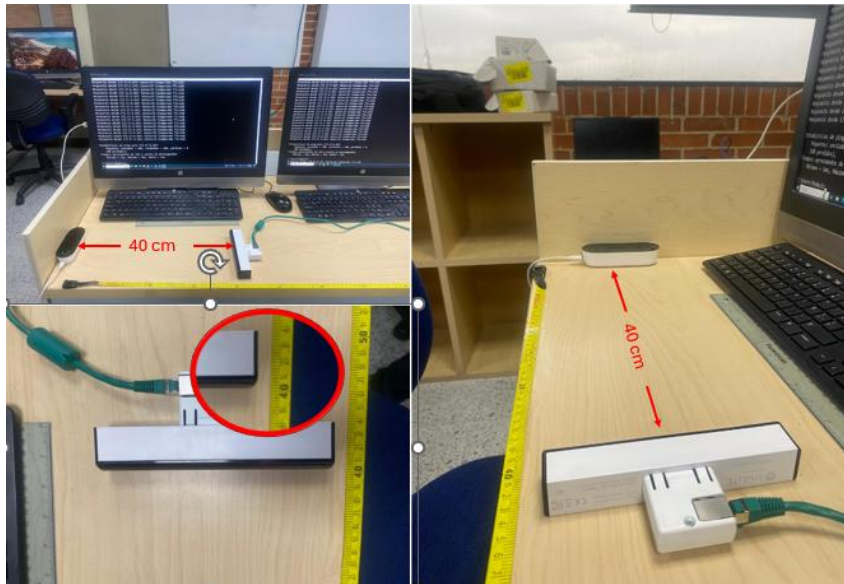

Source: Own work

In **Figure 4**, the evidence of both the ping tests and the measurements is shown, with distances of 20 cm, 40 cm, 60 cm, and 80 cm in an indoor environment under natural light between the time frame of 1-4 pm. For Scenario B, **Figure 5** shows the results under artificial light (with lamps on in the area). **Figure 6** presents the evidence for Scenario C, where there is no light source, neither artificial nor natural.

Figure 4. Connection Test Results - Trulifi 6002 Indoor. Scenario A

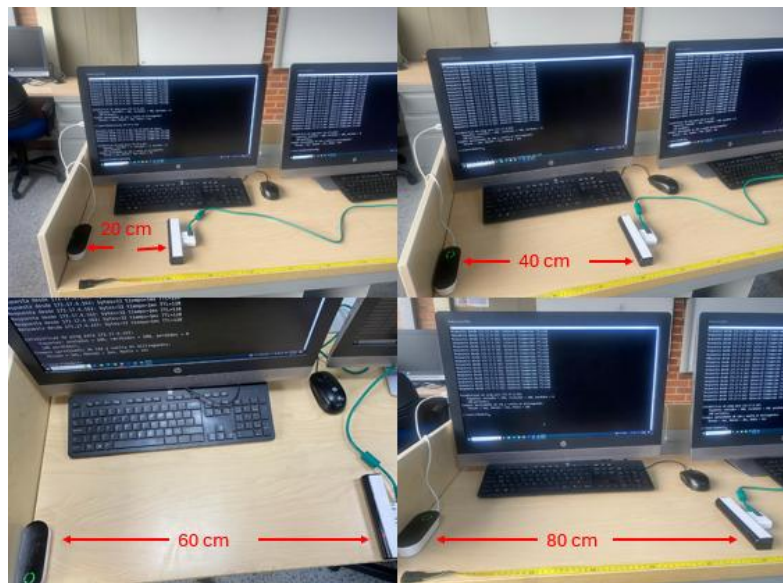

Source: Own work

Figure 5. Connection Test Results - Trulifi 6002 Indoor. Scenario B

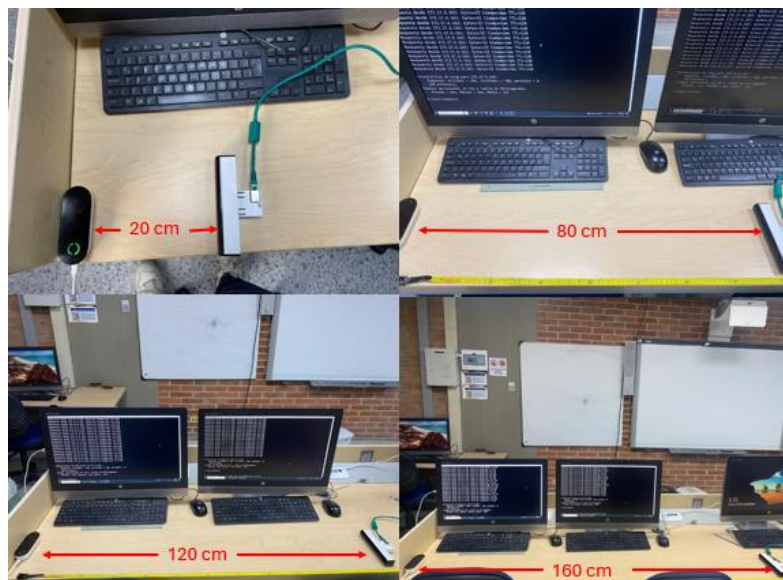

Source: Own work

Figure 6. Connection Test Results - Trulifi 6002 Indoor. Scenario C

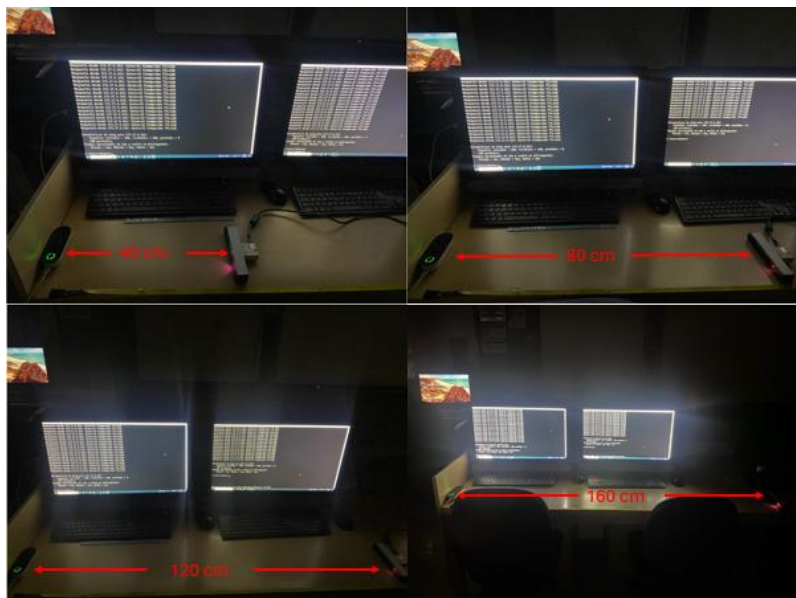

Source: Own work

Finally, **Figure 7** demonstrates the test confirming that the technology is strictly L.O.S (Line-of-Sight). In the top left corner of the figure, a sustained ping is sent, validating a stable connection. When an object is placed between the Trulifi® 6002.1 Infrared Transceiver and the Trulifi® USB Key 6002.1, the communication is lost. However, as seen in the top right corner, when the object is removed from the line of sight, the connection is immediately re-established

Figure 7. Connection Test Results - Trulifi 6002 Indoor. LOS Scenario



Source: Own work

3.3 Analysis and Results

Once the tests described in the previous section were conducted, Table 2 summarizes the main results obtained from the tests in Scenarios A, B, and C. A connection was established for all scenarios; for Scenarios A and C, a maximum distance of 2.4m was confirmed, while for Scenario B, a maximum connection distance of only 2.2m was achieved. For Scenarios A and B, the round-trip time significantly increased after 1.4m for both the transmitter and receiver. In Scenario C, the results were ideal, with stable transmission achieved for all defined distances, showing an average response time of 1ms at the transmitter.

The highest average response time for Scenario A was 1853ms (2.2m) and 1675ms (2.4m) for Tx and Rx, respectively. For Scenario B, the response times were 2766ms (2.2m) at Tx and 2543ms (1.8m) at Rx. In Scenario C, the response time was 374ms (2.4m) at Tx and 389ms (2.4m) at Rx. These results lead to the conclusion that Scenario C, in the absence of light, had the best performance across all evaluated parameters. On the other hand, the

packet loss percentage increased beyond 1.6m for Scenarios A and B, and the relationship between response time and distance was directly proportional, increasing as the distance between the transmission points grew.

Table 2. Results for the 3 Li-Fi Scenarios (A: Natural Light, B: Artificial Light, C: Darkness)

Características Prueba		Transmisor				Receptor			
N° Prueba/Tip o de Prueba	Distancia (cm)	Tiempo Ida y Vuelta promedio (ms)	Tiempo Ida y Vuelta mínimo (ms)	Tiempo Ida y vuelta máximo (ms)	Porcentaje paquetes perdidos (%)	Tiempo Ida y Vuelta promedio (ms)	Tiempo Ida y Vuelta mínimo (ms)	Tiempo Ida y vuelta máximo (ms)	Porcentaje paquetes perdidos (%)
1 Indoor A	20	1	1	1	0	1	1	1	0
2 Indoor A	40	1	1	1	0	1	1	2	0
3 Indoor A	60	1	1	2	0	1	1	2	0
4 Indoor A	80	1	1	2	0	1	1	2	0
5 Indoor A	100	1	1	2	0	1	1	2	0
6 Indoor A	120	1	1	2	0	1	1	2	0
7 Indoor A	140	3	1	1	0	4	1	1	0
8 Indoor A	160	241	1	2724	0	334	1	2754	0
9 Indoor A	180	827	1	3536	27	804	1	3378	14
10 Indoor A	200	1024	2	3056	34	1209	3	3865	49
11 Indoor A	220	1853	3	4368	53	1645	4	4472	62
12 Indoor A	240	1576	4	6785	76	1675	3	7657	85
13 Indoor B	20	1	1	2	0	1	1	2	0
14 Indoor B	40	1	1	2	0	1	1	2	0
15 Indoor B	60	1	1	2	0	1	1	2	0
16 Indoor B	80	1	1	2	0	1	1	2	0
17 Indoor B	100	1	1	2	0	1	1	2	0
18 Indoor B	120	1	1	2	0	1	1	2	0

19 Indoor B	140	1	1	2	0	1	1	2	0
20 Indoor B	160	189	1	1633	0	199	1	1949	0
21 Indoor B	180	226	1	1865	0	2543	1	2145	0
22 Indoor B	200	1087	2	3829	47	891	4	3830	51
23 Indoor B	220	2766	4	7853	86	1879	5	6782	92
24 Indoor B	240	-	-	-	-	-	-	-	-
25 Indoor C	20	1	1	1	0	1	1	1	0
26 Indoor C	40	1	1	2	0	1	1	2	0
27 Indoor C	60	1	1	2	0	1	1	2	0
28 Indoor C	80	1	1	2	0	1	1	2	0
29 Indoor C	100	1	1	2	0	1	1	2	0
30 Indoor C	120	1	1	2	0	1	1	2	0
31 Indoor C	140	1	1	2	0	1	1	2	0
32 Indoor C	160	1	1	2	0	1	1	2	0
33 Indoor C	180	1	1	2	0	1	1	2	0
34 Indoor C	200	1	1	2	0	1	1	2	0
35 Indoor C	220	2	1	5	0	3	1	10	0
36 Indoor C	240	374	1	1960	0	389	1	389	0

Source: Own work

4. Conclusions

Upon analyzing the results obtained in this research on the performance of the Li-Fi technology with the Trulifi 6002, it can be determined that the Li-Fi signal has a more limited coverage compared to technologies like Wi-Fi, as it relies on line-of-sight. However, in small closed spaces, it becomes a good alternative.

The response time measurements used in the different scenarios allowed for the identification of constant times, indicating a stable connection. Variations in response time were noticeable in the presence of obstacles and fluctuations in lighting. The Trulifi 6002-based network performed well in indoor environments, achieving connectivity at a maximum distance of 2.4m.

The infrared lights used in the Trulifi 6002 are less susceptible to interference from ambient light and depend directly on the environment where the network is implemented. Coverage is limited by light propagation and the presence of physical obstacles. Natural light constantly varies in intensity and spectrum, which can cause fluctuations in the Li-Fi signal. Artificial light, on the other hand, provides a more stable and predictable light source. In the

case of Scenario C, the longest range was achieved, while in Scenario A, the results showed more variation due to the changing environmental light conditions directly affecting the performance. Scenario B showed consistent results but with a shorter range.

Acknowledgments

Product derived from the MAXWELL research seedbed, GISSIC Research Group. Universidad Militar Nueva Granada - Vigencia 2025

References

- [1] Barreto Zamora, E. A., & Poveda Carvajal, J. A. (2019). Desarrollo e implementación de librerías para transmisión de información mediante dispositivos multiplataforma usando tecnología li-fi.
- [2] Arunachalam, P., & Kumar, N. (2018, February). Visible light communication and radio network for vehicular environment. In 2018 Second International Conference on Advances in Electronics, Computers and Communications (ICAIECC) (pp. 1-5). IEEE.
- [3] S. Rajagopal, R. D. Roberts and S. -K. Lim, "IEEE 802.15.7 visible light communication: modulation schemes and dimming support," in IEEE Communications Magazine, vol. 50, no. 3, pp. 72-82, March 2012, doi: 10.1109/MCOM.2012.6163585
- [4] Kumar, S., Singh, P. A Comprehensive Survey of Visible Light Communication: Potential and Challenges. *Wireless Pers Commun* 109, 1357–1375 (2019). <https://doi.org/10.1007/s11277-019-06616-3>
- [5] H. Haas, L. Yin, Y. Wang and C. Chen, "What is LiFi?" in *Journal of Light wave Technology*, vol. 34, no. 6, pp. 1533-1544, 15 March 15, 2016, doi: 10.1109/JLT.2015.2510021.
- [6] Dimitrov, Svilen & Haas, Harald. (2015). Principles of LED Light Communications: Towards Networked Li-Fi. 10.1017/CBO9781107278929.
- [7] Badeel, R.; Subramaniam, S.K.; Hanapi, Z.M.; Muhammed, A. A Review on LiFi Network Research: Open Issues, Applications and Future Directions. *Appl. Sci.* 2021, 11, 11118. <https://doi.org/10.3390/app112311118>

- [8] Commercial Lighting Company - Commercial LED, "Trulifi 6002 Access Point Instruction Manual." [Online]. Available: <https://www.signify.com/global/innovation/trulifi/downloads>.
- [9] J. Pradhan, V. K. Kappala and S. K. Das, "Performance Analysis of a Li-Fi System under Ambient Light Conditions," 2020 National Conference on Communications (NCC), Kharagpur, India, 2020, pp. 1-6, doi: 10.1109/NCC48643.2020.9056061
- [10] H. Yuksel and Ö. Altunay, "Host-to-host TCP/IP connection over serial ports using visible light communication," Phys. Commun., vol. 43, p. 101222, 2020. ISSN 1874-4907, doi: <https://doi.org/10.1016/j.phycom.2020.101222>.
- [11] D. Dinev, V. Aleksieva and H. Valchanov, "Study of Li-Fi Indoor Network Reliability," 2020 21st International Symposium on Electrical Apparatus & Technologies (SIELA), Bourgas, Bulgaria, 2020, pp. 1-4, doi: 10.1109/SIELA49118.2020.9167053.
- [12] M. R. Ghaderi, "LiFi and Hybrid WiFi/LiFi indoor networking: From theory to practice," Opt. Switch. Netw., vol. 47, no. July 2022, p. 100699, 2023. ISSN 1573-4277, <https://doi.org/10.1016/j.osn.2022.100699>.
- [13] A. Kabir, M. T. Ahammed, C. Das, M. H. Kaium, M. A. Zardar and S. Prathibha, "Light Fidelity (Li-Fi) based Indoor Communication System," 2022 International Conference on Advances in Computing, Communication and Applied Informatics (ACCAI), Chennai, India, 2022, pp. 1-5, doi: 10.1109/ACCAI53970.2022.9752567.
- [14] P.-T.-M.-P. System, "Trulifi 6002", Signify.com. [Online]. Available: <https://www.assets.signify.com/is/content/Signify/Assets/signify/global/20220811-4422-952-01200-590-e-trulifi-6002-1-system-technical-specification.pdf>.
- [15] Signify.com.[Online].Available:<https://www.assets.signify.com/is/content/Signify/Assets/signify/global/20210128-4422-947-86223-460-trulifi-6002-2-system-installation-instructions.pdf>.