

Reverse engineering for electronic devices: temperature and soil moisture case

Ingeniería inversa para dispositivos electrónicos: estado de temperatura y humedad del suelo

Sergio Alejandro Vaca ¹, Esteban Serrano Vivas ², Jorge Eliécer Rangel Díaz ³

Cite this article as: S. A. Vaca, E. Serrano-Vivas and J. E. Rangel-Díaz, “Reverse engineering for electronic devices: temperatura and soil moisture case”, *Visión electrónica, algo más que un estado sólido*, vol. 13, no. 1, january-june 2019. DOI: <https://doi.org/10.14483/22484728.14404>

Abstract: The measurement of environmental variables turns out to be a wide field in which different techniques are used to capture the desired analog signals, all of the above in order to transform them and deliver them in such a way that their interpretation is clear. This article describes a research project, which was carried out for the Institute of Hydrology, Meteorology and Environmental Studies IDEAM –Colombia–, where a reverse engineering methodology was implemented aimed at the application of proprietary technologies to generate a new device capable of measuring soil temperature and moisture, starting from the design of the electronic

¹ BSc. In Engineering in automation, Universidad de La Salle, Colombia. MSc. (c) In Agricultural engineering, Universidad Nacional, Colombia. E-mail: svacav@unal.edu.co. ORCID: <https://orcid.org/0000-0003-2006-4813>.

² BSc. In Engineering in automation, Universidad de La Salle, Colombia. E-mail: est.2207@gmail.com. ORCID: <https://orcid.org/0000-0002-7522-8531>.

³ BSc. In Physics, Universidad Pedagógica, Colombia. BSc. In Electronic engineering, Universidad Manuela Beltrán, Colombia. MSc. In Physics, Universidad Pedagógica, Colombia. Ph.D. In Mechanical engineering, Universidade Federal de Uberlândia, Brasil. Current position: Professor at Universidad de La Salle, Colombia. E-mail: jorangel@unisalle.edu.co. ORCID: <https://orcid.org/0000-0001-7746-8232>.

A Research Vision

circuit and arriving at the simulation. All based on existing equipment for the identification of electronic components, performance curves, and input and output signals, this with the aim of conceptualizing and generating bases for the final design.

Keywords: Electronic device, Reverse engineering, Sensor, Soil, Temperature and moisture.

Resumen: La medición de variables ambientales resulta ser un campo amplio en el cual se hace uso de diferentes técnicas para lograr captar las señales análogas deseadas con el fin de transformarlas y entregarlas de forma tal que su interpretación sea clara. El presente artículo describe los resultados del proyecto de investigación realizado para el Instituto de Hidrología, Meteorología y Estudios Ambientales IDEAM –Colombia–, donde se implementó una metodología de ingeniería inversa encaminada a la aplicación de tecnologías propias para generar un nuevo dispositivo capaz de realizar la medición de temperatura y humedad del suelo partiendo del diseño del circuito electrónico y llegando a la simulación. Todo lo anterior basándose en un equipo existente para la identificación de componentes electrónicos, curvas de comportamiento, y señales de entrada y salida, con el objetivo de conceptualizar y generar bases para el diseño final.

Palabras clave: Dispositivo electrónico, Ingeniería inversa, Sensor, Suelos, Temperatura y humedad.

1. Introduction

The Institute of Hydrology, Meteorology and Environmental Studies IDEAM, within its wide range of devices for measuring environmental variables, specifically those focused on



*Preparación de Artículos revista VISIÓN ELECTRÓNICA: algo más que un estado sólido
Fecha de envío: 28 de noviembre de 2018
Fecha de recepción: 7 de diciembre de 2018
Fecha de aceptación: 20 de diciembre de 2018*

A Research Vision

measuring soil moisture, has to its credit the TRIME-EZ transducer from IMKO [1], which throughout its period of operation has shown, according to reports from the institute, to have problems with data acquisition, possibly for two reasons: I) Due to the different environmental conditions of the working environments to which the equipment is subjected, which in spite of the fact that most of them comply with the characteristics of the frame with a degree of protection IP68 (resistance to dust and water) [2], they present filtrations and consequently the internal components are affected. II) Lack of protocols for the field connection of devices and improper handling by the operators, since no sequential and/or specific steps are followed for the configuration between the data acquisition system and the transducer, including the configuration of the software and the wiring. All of the above resulting in a substantial loss of information, money and equipment.

It is for the above reasons that the following project focuses on performing a thorough inspection of the equipment in question, applying reverse engineering methodologies for the identification of characteristics such as its physical composition (including internal electronic components and external physical components) and its behavior under operation (physical principles of operation, accuracy, veracity and precision), thus generating a complete report of the equipment, identifying problems to be solved and advantages that can be adapted to the final design.

In order to provide a solution to each of the problems encountered, and to the stages mentioned above, the main objective was design an electronic device for the measurement of soil temperature and moisture from the analysis of an existing IDEAM equipment (Since the TRIME-

A Research Vision

EZ device does not include temperature measurement). Deriving the specific objectives corresponding to the characterization of the device for measuring soil temperature and moisture and the design and simulation of an electronic circuit schematic to, in later works, complete the construction in PCB.

As it has been observed in previous investigations, inverse engineering is implemented according to the follow up of certain directives to carry out the dissection of damaged devices or equipment, that is why through the use of an integral methodology, based on several works that involve inverse engineering, and complementing them with the implementation of a data analysis, it is possible to reinforce the report of the equipment in question, in order to clearly visualize the operation, in several aspects, of the device.

From reverse engineering, all the information is available as a reference to produce a new electronic device, in order to integrate new features that solve problems detected throughout the identification of the equipment, thus carrying out a design stage of the circuit, which integrates parts such as signal acquisition and amplification, treatment to eliminate noise and other unwanted variables, ending with the processing and conversion of the signal to a standard type (0-20 mA, 4-20 mA, 0-1 V, 0-5 V) [3], for later reading in the data acquisition system NetDL 1000 (Datalogger).

2. Background

Based on the consultations carried out is obtained the structure that will be followed throughout the methodology, this is why it is composed of the following elements: Reverse engineering,

A Research Vision

signal transformation, planning of a manufacturing process (flow diagrams), circuit design (block diagrams) and ending with the characterization of sensors.

Starting from one of the main ideas of the project, is the concept of reverse engineering, it is according to this that begins the search for the uses that have been given.

In the field of education this has been used as a methodology in training for innovation [4], giving an analysis from the theoretical part, describing a tree of concepts that is derived from the different uses that can be given to reverse engineering, showing how to understand an engineering product, raise hypotheses, review physical concepts and conduct experimentation to validate the hypotheses, proposing improvements on the design, construction and operation of the product. From this document, reverse engineering is understood as an active learning methodology, where practices are carried out to verify models.

In an example shown by [4], a product for commercial use (Frequency Inverter) is selected, following a methodology that, as a starting point, includes the reading of manuals, then performance tests, proceeding to hypothesize, finally elaborating a black box model to understand the product as a system of inputs and outputs.

Then, with the conceptualization done, the product is disassembled observing the safety precautions and documenting the process, grouping in subsystems, components, functions, interactions and energy flows. According to the above, the physical principles that govern the work of each component are proposed; with these and through experimentation the proposed diagrams are validated. All of the above gives a starting point for the procedure to be followed

A Research Vision

throughout the first stage, which consisted of the characterization of the existing device, thereby opening the next, the design and simulation of the electronic device.

The design of electronic devices is a task that requires different studies depending on the variable to be measured, this is why within the repertoire of references found for this project, are studies focused on the transformation of mechanical signals to electrical as shown by the work of design, construction and characterization of a sensor to measure stress loads by extensometry [5], where are observed proposed manufacturing methodologies of the device, the selection of materials and the equipment used for its elaboration, based on a complete study of how this type of signals are acquired, passing through the conditioning of these and arriving at the conversion for an appropriate reading by the data acquisition card, highlighting the integration of a system for the characterization of the equipment, thus allowing the identification of discrepancies between the manufactured equipment and a standard or reference so that in this way it can be calibrated and have a reliable measure at the time of carrying out tests with the device.

These works give an idea of how a manufacturing process can be approached, establishing measurement ranges according to the need and consequently selecting materials that adapt the sensor signal and allow the construction of the final device.

It is at the end of this design stage, that is encountered one of the essential parts of the project, the creation of a circuit capable of translating the signal coming from the sensor, here is taken into account different references, in which the stage of creating the circuit begins with a block diagram of the system, where you can generate a clear picture of how the signal passes through

A Research Vision

each of these, an example with which most of these projects can be identified is the development of the CR1215 photovoltaic controller for use in photovoltaic solar systems [6], which shows different selection and/or development criteria, bringing together the main characteristics of photovoltaic controllers, and giving them a field within the block diagram (Figure 1).

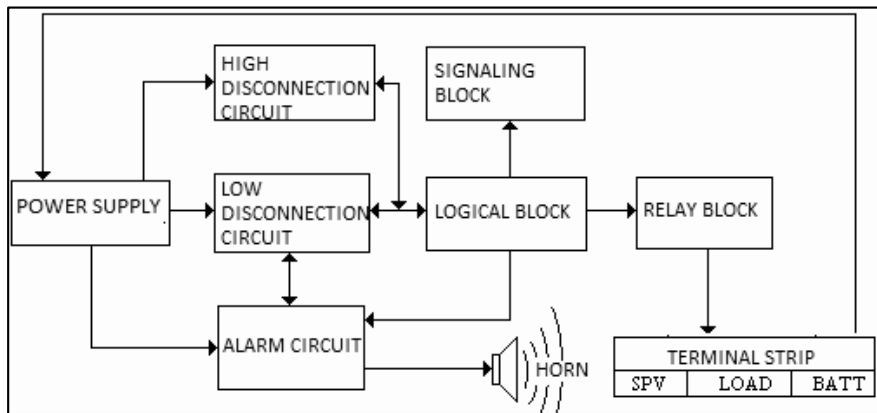

Figure 1. Block diagram of a photovoltaic controller [6].

As shown in Figure 1, blocks are included with the functionality of each one, simplifying the vision of the complete circuit, and sectioning each region of the system in an organized and easy to understand way, making known the treatment that is done to the desired signal to convert it to the scale required by the equipment or instrument, all of the above developing each of the blocks separately, generating the circuit necessary to fulfill its function, so that each part of the system can be tested separately and arrive at a final design in which all the planned blocks are included.

Finally, is made a reference to one of the base articles for the realization of this work, the SDHS Project: Soil Moisture Sensor [7], in which a compilation of the known techniques for soil



Preparación de Artículos revista VISIÓN ELECTRÓNICA: algo más que un estado sólido
Fecha de envío: 28 de noviembre de 2018
Fecha de recepción: 7 de diciembre de 2018
Fecha de aceptación: 20 de diciembre de 2018

A Research Vision

moisture measurement can be observed, including a soil analysis and how each type can affect the measurements according to the implemented method, adding the process of testing and data collection, where special reference is made to the frequencies that this type of sensors can handle, in addition to carrying out a conceptualization of the electrical modeling of soils, finishing with the design of the circuit to be implemented with the respective analysis of failures and corrections to be implemented. This project provides a solid start to achieve the methodology and especially to conceptualize in a broad way several of the elements to be implemented in the design of the soil temperature and moisture sensor shown in this work.

3. Methodology

Thanks to the background and the revision of concepts, a methodology based on a flowchart was implemented. It is represented in two stages (Figure 2) (in accordance with each of the objectives), selected in such a way that reverse engineering studies are complemented along with the circuit design, allowing a comparison between the equipment used in IDEAM and the design created from the project.

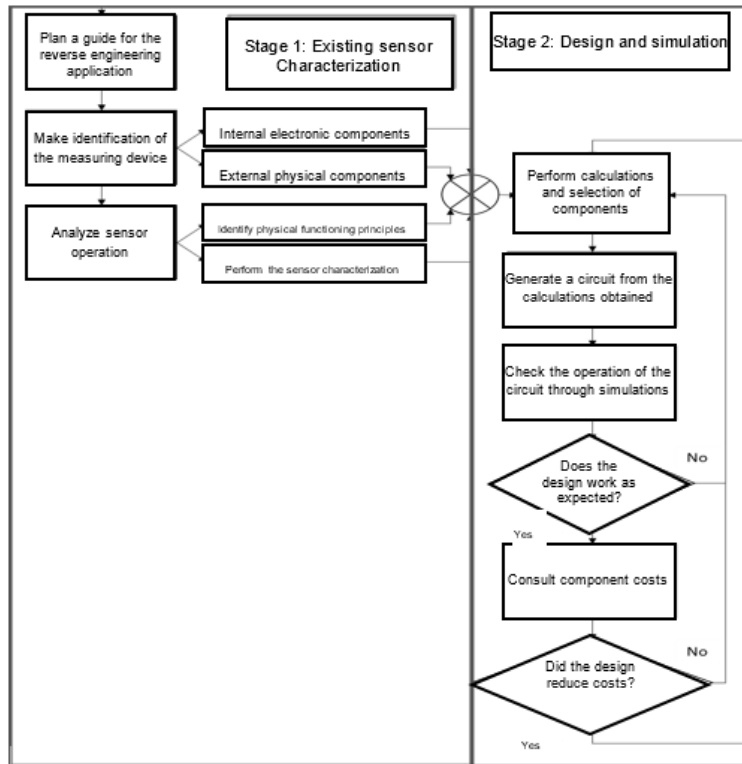

Figure 2: Methodology by stages. Source: own.

Stage 1: Characterization of the soil temperature and moisture measuring device in IDEAM.

- Application of inverse engineering on the device.
- Identification of electronic components, physical components and physical principles of operation.
- Characterization of the device.

Stage 2: According to ISO/IEC 7816 standards of 2011, design of an electronic circuit schematic for later construction, guided by the integrated circuit board guidelines.

- Circuit diagramming and component selection.
- Carrying out calculations.

- Simulation of the circuit and verification of calculations.
- Verification of component and circuit manufacturing costs.
- Comparison of data obtained with calculations and simulations.

3.1. TRIZ Methodology

Different generic solutions in the industry have been studied as part of the development of methodologies to solve problems, Atshuller collected different examples of the repeated use of the same solutions, thanks to this are obtained a compilation of 40 principles, standard solutions for innovation, each one with its own sub principles. The 40 principles are a tool of the Inventive Problem Solving Theory developed in Russia as an algorithm based on the study of global literature, analyzing patterns of invention and lines of technological evolution for the use of all areas of science and technology [8].

Based on the above, the 40 principles of the methodology were analyzed to identify which can be applied to the development of this project [9]. After the identification 7 principles were arrived at, which are:

- Segmentation: Consists of dividing an object or system into independent parts. In this project this principle is used for the dissection of the TRIME-EZ device, separating the structure (encapsulation, insulators, connectors, probes and electronic device), identifying its functions and gathering information.
- Separation: Separates the parts necessary for the development, using only a part of the system, property or characteristic. Throughout the project, thanks to separation and



*Preparación de Artículos revista VISIÓN ELECTRÓNICA: algo más que un estado sólido
Fecha de envío: 28 de noviembre de 2018
Fecha de recepción: 7 de diciembre de 2018
Fecha de aceptación: 20 de diciembre de 2018*

A Research Vision

segmentation, the useful parts for the development of the new device are identified, resulting in the reuse of the probes to capture soil moisture, and discarding the electronic device (due to the lack of diagrams and reference of components) along with the structure (due to destructive dissection).

- Local quality: This principle is based on making the system take advantage of each of its parts, filling a different and useful function. After the identification of the physical principles under which the TRIME-EZ device operates, and taking the probes as a reference, its structure is used, giving it a function in the design of the new electronic device.

- Combine and Multifunctionality: Assemble parts to perform parallel operations, making the system execute multiple functions. During the development of the project, and as a requirement for IDEAM, the temperature measurement is included, which in consequence with the mentioned in local quality must be combined with the soil moisture transducer to take advantage of the space, working in parallel and making the device multifunctional.

- Change the appearance: Converts a variable into a useful one for the system. In this project it is applied throughout the design of the new device, both in terms of moisture and temperature, allowing the capacitance and temperature of the soil to be captured and converted to a standard 4-20 mA signal.

4. Results and discussion

4.1. Sensor characterization

Having the equipment found in IDEAM (Figure 3), the identification process began, looking for documentation and references about the equipment, this to identify the functions, connection diagrams and configuration.



Figure 3. TRIME-EZ Soil Moisture Sensor. Source: own.

As a first step, and consulting the reference of the equipment, a revision was made in the manufacturer's page, finding the user's manual [1], from which it was possible to collect important operating data Table 1.

Power supply	7 V-15 V-DC
Power supply current	8 mA standby
	200 mA during measurement
Measuring range	0-100% volumetric water content
Accuracy	In a range of 0-40% it is 1%.
	In a range of 40-70% it is 2%.
	Repeatability of 0.3%.
Conductivity range	0-1.5 dS/m
Conductivity range in water	0-10 dS/m
Calibration data	Free configuration
Cable length	5 m
Degree of protection	Water resistant seal PVC (IP68)

Table 1. Technical data TRIME-EZ [1].

In addition, they are also found:

- Functional description
- Physical description
- Connection diagram

4.1.1. Performance curve

The dielectric properties of the soil are the main characteristic for moisture percentage measurement. When capacity is measured, it can be related to a dielectric constant, so a model can be applied to estimate soil moisture, all of the above based on an approximation of the distance between the probes and the dielectric that separates them, resembling a parallel plate capacitor.

For the characterization of the equipment provided by IDEAM (TRIME-EZ) several considerations were taken into account, listed below:

- A PCU12 [10], which delivers 14 V, was used as the power supply.
- To read the data, a NetDL1000 [11] datalogger was used, which takes the current variation of 0-20 mA and converts it to percentage of soil moisture by programming.

Initially the soil moisture data were taken using an assembly, in which approximately 950 gr of kiln-dried earth were added to a cylindrical container which has a size according to the length of the probes and the distribution area of the electric field.

After assembly, controlled amounts of water of approximately 5 ml were added to obtain the resolution of the instrument (taking ten data to make an average Table 2), resulting in a resolution of 0.65% soil moisture.

Soil moisture percentage	1,49	0,15	0,48	0,79	0,19	0,97	0,3	0,39	0,98	0,29
---------------------------------	-------------	-------------	-------------	-------------	-------------	-------------	------------	-------------	-------------	-------------

Table 2. Data to obtain resolution. Source: own.

On the other hand, a behavior curve was generated (Figure 6) varying the minimum quantities of water obtained previously, sweeping moisture from 0 to 100%, i.e. the total range of the equipment; in addition to this, and from the terminals of the datalogger, current data was taken (Figure 5) to make a comparison later in the project.

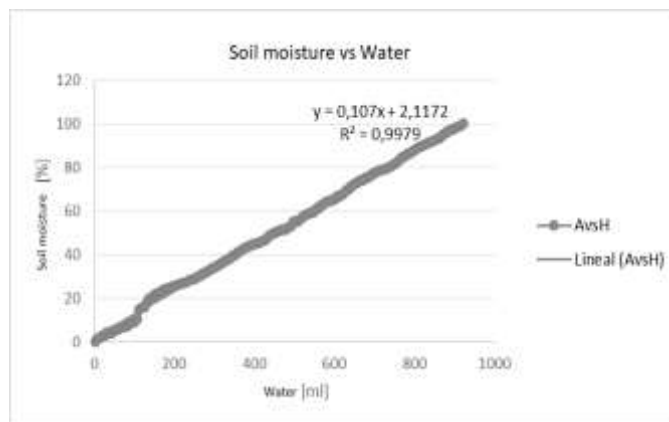
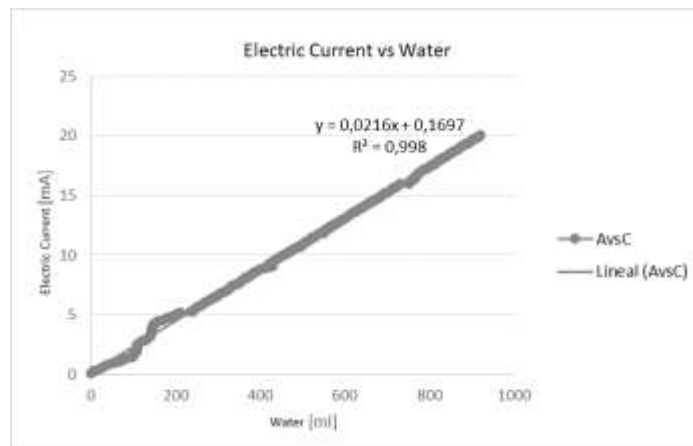

Figure 4. Performance curve of the soil moisture percentage according to the amount of water in the soil. Source: own.



A Research Vision

Figure 5. Performance curve of output current according to its quantity of water. Source: own.

As can be seen, the graph in Figure 4 is linear, starting from 0% with 0 ml of water (container with dry soil), passing through 50% with 460 ml of water and ending in 100% with 920 ml of water, verifying what IDEAM said, i.e. that the equipment is calibrated with the national standard.

In addition to the above, it was possible to calculate the characteristic equation (which also represents the sensitivity of the device) and its square R value according to the linear regression used, which allows (if calibration by program is implemented), to adjust the values of the equation.

In a similar way, we find the current data, which correspond to the same water volume values, showing a similarity between the graphs in Figures 4 and 5, which is due to the ratio of soil moisture to the output current delivered by the instrument.

On the other hand, for precision and repeatability tests, the ability of the instrument to reproduce the same measurement was evaluated when the same input values are applied and under the same conditions.

With the same assembly, but starting from a 1:1 ratio of water and soil, i.e. approximately 50% moisture, the data written in Table 3 were obtained as a result.

Soil moisture percentage	50,48	50,57	50,58	50,53	50,38	50,38	50,34	50,24
---------------------------------	--------------	--------------	--------------	--------------	--------------	--------------	--------------	--------------

Table 3. Data for precision calculation. Source: own.

A Research Vision

With the results from Table 3, precision is then calculated using the equation of mean and mean absolute deviation (MAD):

Replacing the values with those obtained in Table 2, with the result:

$$mean = \frac{\sum \% \text{ soil moisture}}{\# \text{ of data}} = 50,43$$

Then, with the value obtained from the previous step, the average of each of the data taken is subtracted. Finally, the mean absolute deviation shown in the equation is performed:

$$MAD = \frac{\sum |mean - \% \text{ soil moisture}|}{\# \text{ of data}} = 0.102$$

Which shows an accuracy of ± 0.102 in the percentage of soil moisture.

4.2. Reverse engineering

After the documentation and characterization stage of the equipment found in IDEAM, the equipment was dissected, which, being of type IP68 (water and dust resistant), had to be destructive, compromising the frame containing the electronic device, with the probes being the only removable parts.

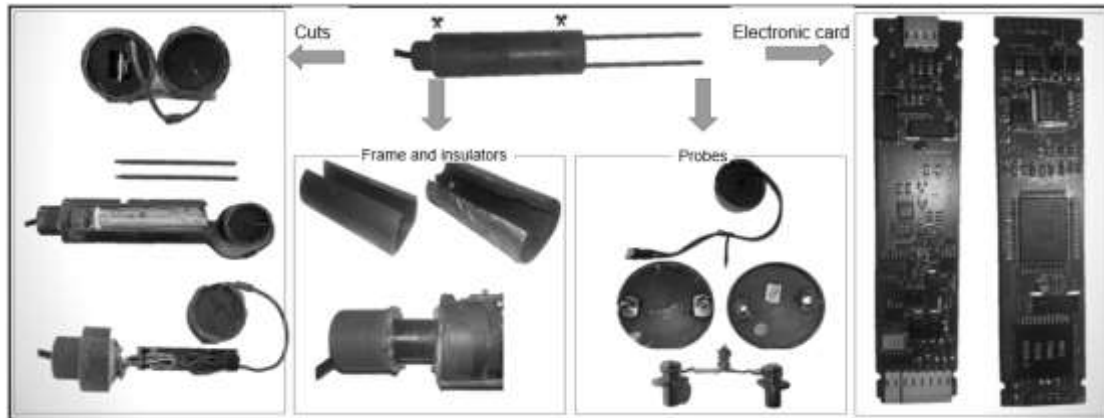

Figure 6. Dissection and classification of TRIME-EZ device elements. Source: own.

As can be seen in Figure 6, dissected elements were classified into three categories:

- Frame and insulators: Where the components whose functionality is to protect all the equipment are gathered.
- Probes: Showing their internal components, in charge of capturing the signal from the ground.
- Electronic card: Composed of surface elements in the card, with a distribution of the paths on and between the layers that compose it.

With the general identification, different characteristics are obtained that are useful at the time of the design from inverse engineering, although the option of reproducing an exact model of the operation of the device is discarded and therefore the data are limited to those obtained with the netDL1000 datalogger, thus requiring a study of the techniques for the measurement of soil moisture.

4.3. Dielectric constant ratio and soil moisture percentage

Within the techniques of soil moisture measurement is the capacitance, the purpose of this method is to measure the apparent permittivity and the dielectric constant of the soil, the dielectric properties of soil are the main characteristic for the measurement of the percentage of moisture. When capacity is measured, it can be related to a dielectric constant, so a model can be applied to estimate soil moisture, all of the above based on an approximation of the distance between the probes and the dielectric that separates them, resembling a parallel plate capacitor.

Thanks to various studies in which dielectric characteristics are modeled, graphs can be found (Figure 7) that demonstrate the relative impact of these on the different working frequencies.

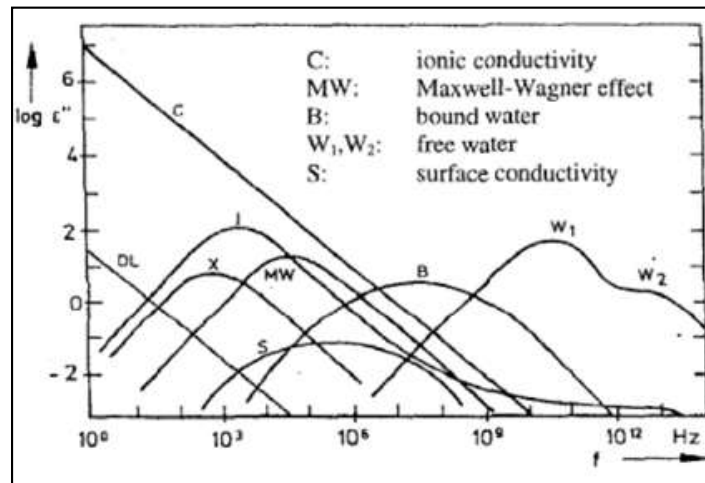

Figure 7. Components in soil polarization related to frequency [12].

As can be seen in the graph in Figure 7, and extracting the useful data for the project, we observe C which represents the ionic conductivity, being directly related to the capacitance and

inversely proportional to the moisture of the soil, that is to say, the lower the capacitance the higher the frequency and vice versa.

4.4. Design and simulation

After compiling all the necessary information about the TRIME-EZ instrument, and observing its specifications, the design and simulation process of the electronic device began, taking into account the new features to be implemented and the reuse of features previously seen during the reverse engineering process, which are mentioned below:

- 14V power supply (supplied by PCU12).
- 4-20mA output (HART standard and NetDL1000 requirement).
- Floor temperature sensor.
- Calibration on the circuit.
- Reuse of soil moisture probes (TRIME-EZ).
- Processor deletion.

4.4.1. Soil moisture and temperature transducer

Initially, approximation tests were generated to acquire the data captured by the probes and transform them into a frequency that can be measured by an integrated for easier treatment.

Through a deeper investigation, it was found that this type of devices handle high frequencies, so it requires a wave generator that handles frequencies of this type, looking for different generators with these features, and performing different tests of readings with them, it was identified that the integrated XR2206 if it produces signals according to the capacitance of the soil with the original probes of the TRIME-EZ.

A Research Vision

With the previous information, we proceeded to design the block diagram (Figure 8) for the conversion of the frequency obtained from the probes with the XR2206 to a current measurement according to the HART protocol to be read by datalogger adjusted to the standard.

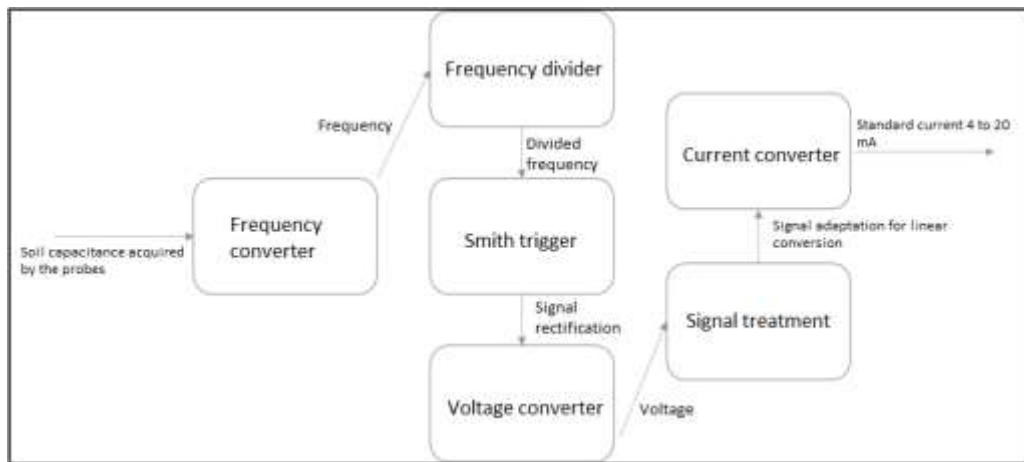

Figure 8. Block diagram for moisture transducer. Source: own.

Displaying the block diagram, it starts from the acquisition of the soil capacitance, converting it to a frequency (square wave signal), which varies according to the value captured by the probes, then this frequency is divided to facilitate its conversion and then passed through a Schmitt trigger which rectifies the wave, improving the quality and avoiding losing resolution in the path of the signal, it is after this that its conversion to voltage is carried out allowing to treat the signal so that in this way it can reach the standardization of the signal, converting it into current from 4 to 20 mA.

Now, referring to one of the new features of the electronic device, is the temperature transducer, which, according to IDEAM, should be included as an extra probe within the previously identified

A Research Vision

in the reverse engineering section, additionally, this must be able to be located at least 80 mm deep, as is how data is currently taken for this variable.

For this reason, it was decided to use a type J thermocouple, reducing the number of integrated devices to be implemented and therefore the cost of their manufacture.

To achieve the objective, a block diagram was generated (Figure 9), including the inputs and outputs of the system, from the acquisition of the signal, to the conversion to a standard type from 4 to 20 mA.

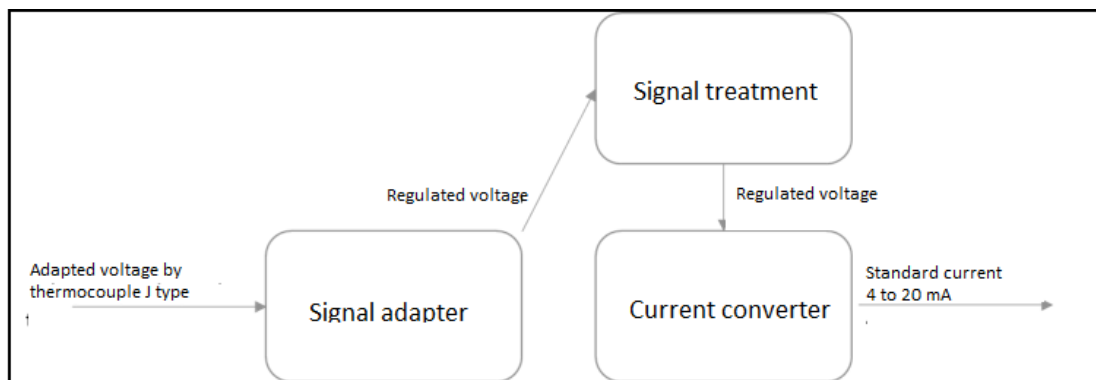

Figure 9. Block diagram for temperature transducer. Source: own.

Displaying the block diagram, it starts from the acquisition of the voltage generated by the thermocouple when the temperature varies, which is in a range of -0.501 mV to 2.585 mV (-10°C to 50°C) according to the tables of the type J thermocouple [13], passing this through a signal adapter to convert the measured voltage into one according to the actual temperature (due to the error generated by the cold junction), then, with the actual voltage, is passed through an amplifier so that this way can be more easily converted to the standard current of 4 to 20 mA.

4.4.2. Simulation

With each one of the block diagrams the theoretical development of each one of these (calculations) was carried out, from which the results thrown by the simulations could be contrasted.

In the first block, that is to say, the acquisition of the soil capacitance, the libraries were not found neither for OrCAD nor for Proteus of the integrated XR2206, that is why the real values obtained from different tests were registered, and then they were used to start from the block of the frequency dividers.

The input values for the frequency division block correspond to a maximum and minimum, the maximum being the value obtained with the air probes and the minimum 100% soil moisture (Table 4).

	Maximum	Dry land	Minimum
Frequency	1.175MHz	1.108MHz	635.6KHz

Table 4. Maximum and minimum frequencies for probes in the air and 100% respectively. Source: own.

It is with these data that the whole simulation is generated, making frequency variations between the delimited ranges.

Each of the blocks has its own simulation, which is why the data were collected in Table 5.

	Minimum	Dry land	Maximum
Amplifier output	5V	8,79V	9,34V
Voltage follower output	5V	8,79V	9,34V
Remaining output	0,5V	5,25V	5,97V
Output current converter	4.02mA	19.8mA	24.1mA

Table 5. Values recorded in simulation for 0% soil moisture (minimum) and 100% soil moisture (maximum). Source: own.

A Research Vision

As it can be observed, in the subtractor stage values are obtained a little higher than expected, so the resistance in the current converter was adjusted, this by making several measurements in the simulation changing the resistance values with a potentiometer.

After the correction, the converter is quite precise as far as the minimum and maximum limits are concerned, in addition to this it is observed that when replacing the values with those obtained in 0% of soil moisture, that is to say in dry ground, it causes the current to decrease, which works to make the adjustment to the HART protocol from 4 to 20 mA.

In the same way, the simulation for the temperature transducer was generated; for the transducer simulation, the entire diagram was assembled in a single file, allowing the complete behavior of the system to be observed. Initially the minimum value for -10°C is taken, then the simulation is carried out with the corresponding value of 0°C, and finally it is generated with a temperature value equal to 50°C, with which the following values recorded in Table 6 are obtained.

	Minimum (-10°C)	0°C	Maximum (50°C)
Thermocouple voltage type J	-0.501mV	0V	2,585V
Output AD595	-0,089V	0,0013V	0,501V
Amplifier output	0,04V	0,49V	5,03V
Output current converter	4.2mA	6mA	19.8mA

Table 6. Values recorded in simulation for temperatures of -10°C (minimum), 0°C and 50°C (maximum). Source: own.

As it can be observed, in the thermocouple type J exact values are obtained, then, entering to the block of the AD595 quite approximate voltages are observed although a little out of phase

A Research Vision

as for the voltages that represent the degrees below zero, later in the amplifier, as it was expected, the minimum voltage is higher than the normal, assigning this to that a single source is handled for the LM324. Finally, the output current is adjusted to capture the negative variation of the temperature, this by making several measurements in the simulation changing the resistance values with a potentiometer, which is added for physical tests performing a calibrator function.

5. Conclusions

Thanks to the identification during the reverse engineering process of the TRIME-EZ sensor, new features were adopted for the design of the new electronic device, such as the moisture measurement method, going from TDR to capacitive, this because the configuration of the probes used in the TRIME-EZ sensor allow the soil capacitance to be measured with them.

Additionally, thanks to the implementation of some reverse engineering principles, the components of the TRIME-EZ sensor were identified, which can be reused in the manufacture of the new electronic device, which are the probes, and the data cables of the sensor, the electronic card was discarded because the manufacturer does not provide information of the components, the insulator and the encapsulation were also discarded because when dissecting the sensor, these elements have to be destroyed to perform this process.

Being in contact with IDEAM allowed to determine the final characteristics of the temperature transducer, and to know the method implemented to make this type of measurements, and was

A Research Vision

used to dimension the probe in the device, which corresponds to a type J thermocouple, which covers the measurement range required for this variable.

Based on the NTC/ISO 10012-7 standard, the pertinent measurements for the calculation of errors, repeatability, precision, resolution and sensitivity could be carried out following an established procedure or protocol, which allowed to give exact values that were used later in the elaboration of the maintenance and operation manual of the device.

References

- [1] IMKO, "TRIME-EZ User manual", 2006.
- [2] IEC, Degrees of protection provided by enclosures (IP Code) IEC 60529, 2014. [Online]. Available: <https://www.nema.org/Standards/ComplimentaryDocuments/ANSI-IEC-60529.pdf>.
- [3] HART, "Hart Communication Application Guide", 2014. [Online]. Available: https://www.fieldcommgroup.org/sites/default/files/technologies/hart/ApplicationGuide_r7.1.pdf.
- [4] D. A. Ramos, "Using Reverse Engineering as a Teaching Methodology in Training for Innovation", World Engineering Education Forum, 2013.
- [5] G. A. Ruiz, "Diseño, construcción y caracterización de un sensor para medir cargas a tensión por extensometría", tesis, Universidad Tecnológico de la Mixteca, 2005.
- [6] J. E. Camejo, R. Pupo and J. Díaz, "Development of the Photovoltaic Controller CR1215 for Its Use in Autonomous Solar Photovoltaic Systems", (APVS) CIES, 1995.
- [7] C. Gustavino, "SDHS Project: Soil Moisture Sensor", 2009.
- [8] G. Altshuller, "Innovation TRIZ", 1956. [Online]. Available: <http://www.innovation-triz.com/triz/>.
- [9] P. Reyes, "Método TRIZ", 2004. [Online]. Available: <http://www.icicm.com/files/MetodoTRIZ.pdf>.
- [10] Hydrometrie, "Operating Instructions Power Control Unit PCU12", 2017.



Preparación de Artículos revista VISIÓN ELECTRÓNICA: algo más que un estado sólido
Fecha de envío: 28 de noviembre de 2018
Fecha de recepción: 7 de diciembre de 2018
Fecha de aceptación: 20 de diciembre de 2018

A Research Vision

- [11] Hydrometrie, “Instruction Manual Data Logger netDL500 and netDL1000”, 2017.
- [12] T. Flaschke and H. R. Trankler, “Dielectric Soil Water Content Measurements Independent of Soil Properties”, IMTC/99. Proceedings of the 16th IEEE Instrumentation and Measurement Technology Conference (Cat. No.99CH36309), 1999. <https://doi.org/10.1109/IMTC.1999.776716>.
- [13] ARIAN, “What are thermocouples and how do they work”, 2006.